



**DUR-A-FLEX**  
INNOVATION FROM THE FLOOR UP

## DUR-A-CHIP SYSTEM

### SUBMITTAL PACKAGE CONTENTS:

- DUR-A-GLAZE MVP PRIMER-PRODUCT DATA SHEET (OPTIONAL DEPENDING UPON MOISTURE TEST RESULTS)
- DUR-A-GLAZE MVP HARDNER – MSDS
- DUR-A-GLAZE MVP RESIN – MSDS
- DUR-A-GLAZE #4 WB PRIMER – PRODUCT DATA SHEET
- DUR-A-GLAZE #4 WB PRIMER – MSDS
- DUR-A-CHIP – PRODUCT DATA SHEET
- DUR-A-CHIP – APPLICATION INSTRUCTIONS
- DUR-A-CHIPSYSTEM – MSDS
- CHIPS MSDS
- ARMOR TOP - PRODUCT DATA SHEET
- ARMOR TOP SYSTEM- MSDS
- MACRO CHIP COLOR CHART
- MICRO CHIP COLOR CHART
- SURFACE PREPARATION GUIDELINES
- FLOOR EVALUATION GUIDELINES
- FLOOR EVALUATION FLOW CHART
- CHEMICAL RESISTANCE CHART
- CLEANING GUIDELINES
- JOINT GUIDELINES
- STANDARD WARRANTY



## DUR-A-GLAZE MVP Primer

### DESCRIPTION

Dur-A-Flex DUR-A-GLAZE MVP PRIMER is a clear, 100% solids epoxy moisture mitigation system formulated to bond to concrete with relative humidity (RH) as high as 95%. It is designed to reduce moisture vapor emission levels up to 20 lbs/1000 sq. ft./24 hours to 3 lbs/1000 sq. ft./24 hours or less.

### BENEFITS

- Reduces moisture levels to 3 lbs./1,000 sq. ft./24hours or less
- VOC 0 g/L
- Typical one coat application
- Excellent adhesion
- Resistant to high Ph

### TYPICAL USES

- Moisture mitigation system under any epoxy-based Dur-A-Flex flooring system
- Primer over Dur-A-Tex 32
- Use with Dur-A-Flex-approved resilient flooring underlayment primers

### LIMITATIONS

- For interior applications only
- Apply only to properly prepared, sound and stable concrete at least 5 days old.
- DUR-A-GLAZE MVP PRIMER is to be applied at substrate temperatures between 60° F and 90° F.
- Do not apply when RH of concrete is greater than 95% (at 40% depth of slab) or moisture vapor transmission levels are greater than 20 lbs/1000 sq. ft./24 hours
- Recoat window of within 24 hours must be adhered to.
- Do not use as a stand-alone system
- Available clear only
- Does not prevent floor failures due to osmotic blistering. See note on this page under WARRANTY.
- Where Dur-A-Glaze MVP is used with vinyl tile, sheet vinyl, carpet, or any other resilient floor covering, the 10 year warranty is only valid if Dur-A-Glaze MVP is used with Dur-A-Flex-approved cementitious underlayment primers.

### APPLICATION METHOD/ SPREAD RATES

Pour 2 parts resin into 1 part hardener and mix for 2 minutes using a jiffler-type mixer at 300 – 450 rpm.

DUR-A-GLAZE MVP PRIMER is applied with a 3/16 inch V-notched squeegee and back-rolled with a 3/8 inch nap roller cover. Apply at a rate of 100 sq.ft./gallon to yield a dry film thickness of 16 mils.

NOTE: Out-gassing may occur in very porous concrete. To address this, apply a second coat of DUR-A-GLAZE MVP PRIMER mixed with an equal amount of Cab-O-Sil. Apply using a flat squeegee at 250 – 350 square feet per mixed gallon.

### SURFACE PREPARATION

This product requires preparation in order to perform as expected. Surface must be profiled, clean, dry, oil free and sound. Please refer to the Surface Preparation Guide on our website for more information.

Perform anhydrous calcium chloride tests per ASTM F1869 for to determine moisture vapor emission rates and/or in situ probe method testing per ASTM F2170 to determine relative humidity levels.

NOTE: If replacing VCT, note that salt concentration is typically higher where tiles meet. Dur-A-Flex highly recommends core analysis along joint lines prior to installation of any resinous floor system.

### PACKAGING

DUR-A-GLAZE MVP PRIMER is available in 1-gallon cans, 5-gallon pails and 50-gallon drums.

### WARRANTY

A 10 year warranty is available for approved applications with the submission of a warranty application form. The form can be found in the Contractor Center on our website.

NOTE: DUR-A-GLAZE MVP PRIMER is a moisture mitigation system designed to reduce moisture vapor emission only. It will not prevent floor failures caused by osmotic blistering unless ionic components (salts) in the substrate are at acceptable levels. An analysis of the substrate may be obtained using the Dur-A-Flex Floor Evaluation/Moisture Guidelines.

**JOINT GUIDELINES**

**Construction, Expansion and Isolation** joints are considered moving joints which allow horizontal and vertical movement between the slab and adjoining structures, such as walls and columns, helping to minimize cracking where the two meet.

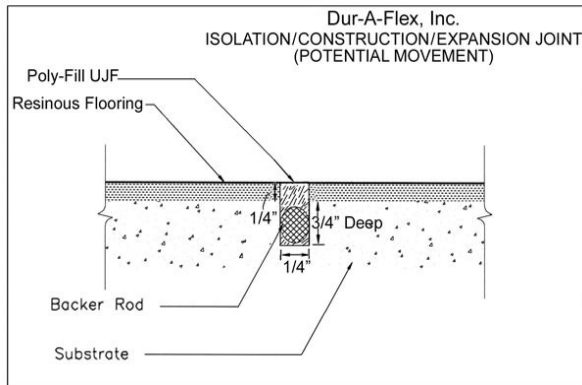

Prior to filling moving joints Dur-A-Flex, Inc. recommends “honoring” these joints by making a saw cut through the finished floor system at a depth of 3/4” deep and 1/4” wide with a diamond blade saw attached to a vacuum. A bond breaker such as backer rod (closed cell) must be added to the bottom of the joint. Use Poly-Fill UJF to fill joint.

**Be sure to mark the location of the joints prior to the installation of the finished floor.**

**Control and or Contraction** joints are considered non-moving joints which accommodate shrinkage and relieve internal stresses during the curing process of the concrete.

Fill joints as follows: Mix 1 part Dur-A-Glaze MVP hardener with 2 parts Dur-A-Glaze MVP resin and thicken with 3 parts Cab-0-Sil.

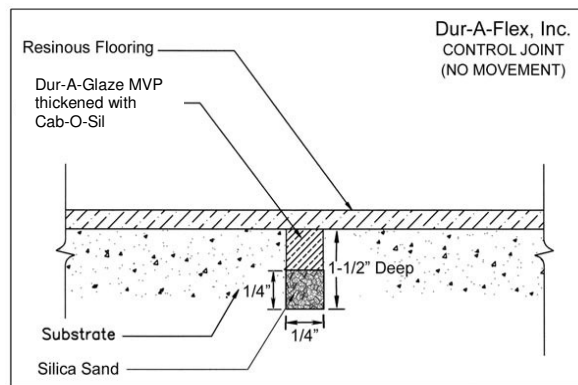

*Before using any Dur-A-Flex, Inc. product, be sure the Material Safety Data Sheet is read and understood.*

**DUR-A-GLAZE MVP PRIMER**

**TECHNICAL INFORMATION**

Resin type	Epoxy
Color	Clear
% Solids	100%
Mix Ratio (by volume)	2 resin to 1 hardener
Viscosity at 70°F (mixed hardener & resin)	1,400 cps
Pot Life at 70°F	45 minutes
Recoat range at 70°F	12 – 24 hours
Foot traffic	24 hours
Cured Film Thickness	16 mils at 100 sq. ft. per gallon
Shelf life	1 year when stored in original packaging at 73° F
VOC	0 g/L

Physical Property	Test Method	Result
Hardness, Shore D	ASTM D-2240	75-80
Compressive Strength	ASTM D-695	11,200 psi
Flame Spread /NFPA-101	ASTM E-84	Class A
Tensile Strength	ASTM D-638	2,100 psi
Flexural Strength	ASTM D-790	5,100 psi
Bond Strength to Concrete	ACI-40	Substrate Failure
Water Absorption	MIL D-24613	Nil







**SECTION VI - HEALTH HAZARD DATA**

Route(s) of Entry:	Inhalation?	Skin?	Ingestion?
	YES	YES	YES

Signs and Symptoms of Exposure      Irritation on skin.

## Health Hazards (Acute and Chronic)

ACUTE - Irritation on skin and dermatitis.

CHRONIC - Repeated overexposure will cause severe skin irritation, dermatitis and sensitization.

Sensitized persons may experience rapid irritation of skin upon exposure.

Carcinogenicity:	NTP?	IARC Monographs?	OSHA Regulated?
	NO	NO	NO

## Medical Conditions Generally Aggravated by Exposure

Allergy, skin disorders.

## Emergency and First Aid Procedures

EYES - Flush with water, holding lids open for 15 minutes or more. Call physician for advice if necessary.

SKIN - PROMPTLY wash with soap and water. DO NOT wash with solvents. Seek medical advice if irritation develops or persists

INHALATION - Move person to fresh air if effects occur. If needed, give oxygen or artificial respiration to improve breathing. Consult physician.

INGESTION - Get medical attention immediately. Never give liquids to an unconscious or convulsing person.

Note: Persons with lung disorders or who are sensitized should not use this product.

**SECTION VII - CONTROL MEASURES**

## Respiratory Protection (Specify Type)

Provide adequate exhaust ventilation; use a NIOSH - approved respirator if PELS/TLVS are exceeded.

Ventilation	Local Exhaust	If needed.	Special	None known.
	Mechanical	Adequate exhaust ventilation must exhaust AWAY from applicator.		

Protective Gloves	Natural or Neoprene gloves.	Eye Protection	Splash goggles or face shield.
-------------------	-----------------------------	----------------	--------------------------------

## Other Protective Clothing or Equipment

Use rubber apron, face shield and appropriate clothing to prevent contact with skin. Launder contaminated clothing before reuse. Discard contaminated leather shoes and canvas sneakers. Protective skin creams help cleaning with soap and water, gloves must be still be worn. An eye wash station or an adequate supply of clean water must be available at work area.

Work/Hygienic Practices      Enforce careful handling to prevent splashing. Wash thoroughly after use.

**SECTION VIII - PRECAUTIONS FOR SAFE HANDLING AND USE**

## Steps to be Taken in Case Material is Released or Spilled

Wear protective equipment to prevent exposure. Stop spill and dike to prevent spreading. Cover spill with absorbent materials and collect into containers. Clean contaminated area with detergent and water or a steam cleaner for best results.

## Waste Disposal Method

Dispose in accordance with Federal, State, and Local requirements.

## Precautions to be Taken in Handling and Storing

Keep containers tightly closed when not in use.

Other Precautions      NONE KNOWN.

Prepared by      Samet Dy - Chemist

**PLEASE NOTE**

"The above information is accurate to the best of our knowledge. However, since data, safety standards, and government regulations are subject to change and the conditions of handling and use, or misuse, are beyond our control, Dur-A-Flex, Inc. MAKES NO WARRANTY, EITHER EXPRESS OR IMPLIED, WITH RESPECT TO THE COMPLETENESS OR CONTINUING ACCURACY OF THE INFORMATION CONTAINED HEREIN AND DISCLAIMS ALL LIABILITY FOR RELIANCE THEREON. User should satisfy himself that he has all current data relevant to his particular use."

## **DUR-A-GLAZE #4 WB PRIMER**

### **DESCRIPTION**

DUR-A-GLAZE #4 WB PRIMER is a water-borne, two component, epoxy designed to prime concrete floors.

### **BENEFITS**

- Low VOC
- Easy to Use
- Long Pot Life
- Low Odor
- Fast Drying
- Excellent Adhesion

### **TYPICAL USES**

DUR-A-GLAZE #4 WB PRIMER is applied clear using **Dur-A-Glaze #4 Resin**.

As a primer for following epoxy systems:

- DUR-A-GARD
- DUR-A-GARD SL
- DUR-A-QUARTZ
- SHOP FLOOR
- DUR-A-CHIP

### **LIMITATIONS**

**This product is designed to be applied at 200 square feet per gallon. Do not apply this product less than 8 mils wet or “out-gassing” can occur.**

Do not use this product to “fill” or “level any surface imperfections. Any build up in excess of 12 mils wet film thickness will not cure properly. Not a UV stable product.

This product is best suited for application in temperatures between 60°F and 90°F. Substrate must be clean, sound, and dry.

Excessive relative humidity of greater than 70% will dramatically prevent migration of water. Proper ventilation to move air is recommended.

Do not use as a stand-alone system.

Protect from freezing. If product freezes, heat-thaw, mix with resin and apply according to instructions.

### **APPLICATION METHOD/SPREAD RATE**

**Mix 4 parts DUR-A-GLAZE #4 WB PRIMER HARDENER to 1 part DUR-A-GLAZE #4 RESIN.**

Recommended spread rate of **200** Sq Ft per gallon mix. Apply with a 1/8” notched squeegee.

Then immediately back roll with a high quality 3/8” nap roller cover. **Be sure to check the spread rate as the material is applied.**

For proper flow and wetting, maintain DUR-A-GLAZE #4 WB PRIMER at room temperature prior to mixing. The hardener and resin should be thoroughly mixed before combining.

Scrape the bottom and sides of each container. The resin and hardener can then be combined and mixed using a **slow**-speed 450 rpm electric drill with a Jiffler type mixing attachment.

2 coats required depending on concrete surface profile.

### **SURFACE PREPARATION**

This product requires preparation in order to perform as expected. Substrate must be roughened, clean, sound, and dry. Please refer to the Surface Preparation guidelines on our website for more information.

### **PACKAGING**

DUR-A-GLAZE #4 WB PRIMER HARDENER is available in 1-gallon cans, 5-gallon pails and 50-gallon drums.

# DUR-A-GLAZE #4 WB PRIMER

## TECHNICAL INFORMATION

Finish:	High Gloss
Cure Time at 70°F (foot traffic)	6-8 hours
Pot Life at 90°F:	30 minutes
Pot Life at 70°F	1 hour
Pot Life at 60°F	1 1/2 hours
Re-Coat Window at 70°F	8 -36 Hrs
Spread Rate, Avg. Concrete:	200 sq. ft./gal. DFT = 5 mils @ 200 ft.
Mix Ratio:	4 part hardener to 1 part resin
Color (cured):	Transparent, Clear
Shelf Life:	1 year, unopened containers

Physical Property	Test Method	Result
VOC Content		2 g/L
Solids by volume		56 % +/-5%
Flexibility (1/4: Cylindrical mandrel)	ASTM D-1737	Pass
Elongation	ASTM D-2370	9%
Impact Resistance	ML D-2794	>160
Hardness	ASTM D-3363	3H
Abrasion Resistance	ASTM D-4060	
CS17 wheel (1000g load)	1000 Cycles	30 mg loss
Adhesion	ASTM D-4541	550 psi (Concrete Failure)
Coefficient of Friction	ASTM D-2047	>0.6
60 Gloss	ASTM D-523	85+

### CAUTION

Follow the Hazardous Materials Identification System labeling guide for proper personal protective equipment to use when handling this product. Use only as directed. **KEEP OUT OF REACH OF CHILDREN.**

### MOISTURE CONCERNS

Please refer to the Floor Evaluation Flow Chart in the Contractor's Center of our website for a step-by-step process to determine the condition of the concrete.

*Before using any DUR-A-FLEX, Inc. product, be sure the Material Safety Data Sheet is read and understood.*



**DUR-A-FLEX**  
INNOVATION FROM THE FLOOR UP

95 Goodwin Street, East Hartford, CT., 06108 (860) 528-9838

# Material Safety Data Sheet

Date Prepared 8/2/2010

## SECTION I - IDENTIFICATION

IDENTITY (As Used on Label) **Dur-A-Glaze #4 WB Primer-Sealer Hardener**

COMMON NAME Emulsified Amine Curative

### HAZARD RATING

0 = Least  
1 = Slight  
2 = Moderate  
3 = High  
4 = Extreme

Health

3

Flammability

1

Reactivity

0

Personal Protection

G

## SECTION II - PRODUCT COMPONENTS

CAS.#

OSHA PEL

ACGIH TLV

Water	7732-18-5	N.E. <sup>1</sup>	N.E.
Polyamine Curative	Proprietary <sup>2</sup>	N.E.	N.E.
Modified Epoxy Resin Adhesion Promotor	Proprietary	N.E.	N.E.

<sup>1</sup>None Established

<sup>2</sup>The manufacturer of the component states that they will provide additional information to a health professional in the event of a medical emergency.

T.S.C.A. Status - O.K. on all above components.

**\*FOR SPILL, LEAK, FIRE, OR ACCIDENT, CALL CHEMTREC 24-HOUR EMERGENCY NUMBER 1-800-424-9300\***

## SECTION III - PHYSICAL/CHEMICAL CHARACTERISTICS

Boiling Point	>400°F	Specific Gravity (H2O = 1)	1.07
Vapor Pressure (mm Hg)	not known	Melting Point	N/A
Vapor Density (AIR = 1)	not known	Evaporation rate (Butyl Acetate = 1)	not known

Volatile Organic Compounds (VOC) = < 2 grams/liter

Solubility in Water Soluble

Appearance and Odor Pale yellow viscous liquid. Mild ester-like odor.

## SECTION IV - FIRE and EXPLOSION HAZARD DATA

Flash Point (Closed Cup Method)	212°F	Flammable Limits	LEL	UEL
			N/A	N/A

Extinguishing Media Water spray, Foam, CO<sub>2</sub>, Dry Chemicals.

Special Firefighting Procedures

Wear full protective equipment including self-contained breathing apparatus.

Unusual Fire and Explosion Hazards

Cool storage containers with water spray to prevent pressure build-up that may rupture the containers.

Combustion products may be toxic.

## SECTION V - REACTIVITY DATA

Stability	Unstable		Conditions to Avoid
	Stable	X	None known

Incompatibility (Materials to Avoid) None known

Hazardous Decomposition or Byproducts By Fire - Carbon monoxide, Carbon dioxide, Nitrogen oxides.

Hazardous Polymerization	May Occur		Conditions to Avoid
	Will Not Occur	X	None known.

**SECTION VI - HEALTH HAZARD DATA**

Route(s) of Entry:	Inhalation?	Skin?	Ingestion?
	YES	YES	YES

Signs and Symptoms of Exposure      Irritation of skin.

Health Hazards (Acute and Chronic)

ACUTE - Irritation of skin and dermatitis.

CHRONIC - Repeated overexposure will cause severe skin irritation, dermatitis and sensitization. Sensitized persons may experience rapid irritation of skin upon exposure.

Persons with lung disorders or who are sensitized should not use this product.

Carcinogenicity:	NTP?	IARC Monographs?	OSHA Regulated?
	NO	NO	NO

Medical Conditions Generally Aggravated by Exposure

Allergy, skin disorders

Emergency and First Aid Procedures

EYES - Flush with water, holding lids open for 15 minutes or more. Call physician for advice if necessary.

SKIN - PROMPTLY wash with soap and water. DO NOT wash with solvents. Seek medical advice if irritation develops or persists.

INHALATION - Move person to fresh air if effects occur. If needed, give oxygen or artificial respiration to improve breathing. Consult physician.

INGESTION - Get medical attention immediately. Never give liquids to an unconscious or convulsing person.

**SECTION VII - CONTROL MEASURES**

Respiratory Protection (Specify Type)

Provide adequate exhaust ventilation; use a NIOSH approved respirator if PELs/TLVs are exceeded.

Ventilation	Local Exhaust	If needed.	Special	None known.
	Mechanical	Adequate exhaust ventilation must exhaust AWAY from applicator.		

Protective Gloves	Natural rubber or Neoprene.	Eye Protection	Splash goggles or face shield.
-------------------	-----------------------------	----------------	--------------------------------

Other Protective Clothing or Equipment

Use rubber apron, face shield and appropriate clothing to prevent contact with skin. Launder contaminated clothing before reuse. Discard contaminated leather shoes and canvas sneakers. Protective skin creams help cleaning with soap and water, but gloves must still be worn. An eye wash station or an adequate supply of clean water must be available at work area.

Work/Hygienic Practices      Enforce careful handling to prevent splashing. Wash thoroughly after use.

**SECTION VIII - PRECAUTIONS FOR SAFE HANDLING AND USE**

Steps to be Taken in Case Material is Released or Spilled

Wear protective equipment to prevent exposure. Stop spill and dike to prevent spreading. Cover spill with absorbent materials and collect into containers. Clean contaminated area with detergent and water or a steam cleaner for best results.

Waste Disposal Method

Dispose in accordance with Federal, State and Local requirements.

Precautions to be Taken in Handling and Storing

Keep containers tightly closed when not in use.

Other Precautions      NONE KNOWN.

Prepared by      Samet Dy - Chemist

**PLEASE NOTE** "The above information is accurate to the best of our knowledge. However, since data, safety standards, and government regulations are subject to change and the conditions of handling and use, or misuse, are beyond our control, Dur-A-Flex, Inc. MAKES NO WARRANTY, EITHER EXPRESS OR IMPLIED, WITH RESPECT TO THE COMPLETENESS OR CONTINUING ACCURACY OF THE INFORMATION CONTAINED HEREIN AND DISCLAIMS ALL LIABILITY FOR RELIANCE THEREON. User should satisfy himself that he has all current data relevant to his particular use."

## **DUR-A-CHIP**

### **DESCRIPTION**

DUR-A-CHIP SEAMLESS FLOORING is a decorative, “poured in place” flooring system consisting of liquid polymers and color-fast decorative chips. DUR-A-CHIP incorporates DUR-A-GARD for the base coat and is grout coated with DUR-A-GLAZE #4 and top coated with ARMOR TOP. DUR-A-CHIP is designed to provide a terrazzo-like appearance. In addition to its seamless cleanability, it requires no waxing. Surface finish can be smooth or slip resistant.

### **BENEFITS**

- Easy Installation
- Low Odor
- Meets USDA, FDA, OSHA standards
- Easy To Use
- Good Abrasion Resistance
- Easy Maintenance

### **COLORS**

DUR-A-CHIP is available in MACRO or MICRO decorative chips. The MACRO and MICRO chips are available in standard and custom multi-color pre-blends. Please refer to the MACRO and MICRO Chip Color Selector Chart.

### **TYPICAL USES**

- Laboratories
- Hospitals
- Rest Rooms
- Lobbies
- Concourse
- Schools
- Pharmaceuticals
- Clean Rooms
- Halls / Corridors
- Retail
- Dining Areas
- Supermarkets

### **SURFACE PREPARATION**

This product requires preparation in order to perform as expected. Substrate must be profiled clean, sound, and dry. Please refer to the master Surface Preparation Guide on our website for more information.

### **APPLICATION METHOD**

See the DUR-A-CHIP application instruction sheet for complete instructions.

### **LIMITATIONS**

This product is best suited for application in temperatures between 60°F and 90°F. Substrate must be clean, sound, and dry.

### **PACKAGING**

DUR-A-GARD and DUR-A-GLAZE #4 are available in 5-gallon pails and 50-gallon drums. ARMOR TOP is available as kits. DUR-A-CHIP is available in 10 lb or in 55 lb boxes.

### **CHEMICAL RESISTANCE**

This product is resistant to most common chemicals. Please refer to master Chemical Resistance Chart on our website for actual resistance to specific chemicals/reagents.

### **JOINT GUIDELINES**

Refer to the Joint Guidelines for complete details on our website.

“Warranties: Seller warrants that its goods, as described on the face hereof, are free from any defects in material or workmanship. Seller makes no other warranty, express or implied, and all implied warranties of merchantability and fitness for a particular purpose are hereby disclaimed. Seller shall not be liable for prospective profits or special indirect or consequential damages. Seller’s sole liability and buyer’s exclusive remedy for breach of any warranty as expressly limited, at seller’s option, to replacement at the original F.O.B. point or refund of purchase price. Seller shall not be responsible for any claim resulting from failure to utilize product in the manner in which it was intended and in accordance with instruction provided for use of product. Any claim for breach of warranty shall be deemed waived unless buyer shall give seller written notice of such claim within sixty (60) days after delivery and shall allow seller reasonable opportunity to investigate claim and inspect product.”

# DUR-A-CHIP

## TECHNICAL INFORMATION

Salt Spray Resistance, 25% solution at 90°F	No effect after 100 hours	
Toxicity	Non-toxic, meets USDA requirements	
Physical Property	Test Method	Result
Hardness, Shore D	ASTM D-2240	75 – 80
Water Absorption	ASTM D-570	0.04%
Flammability	ASTM D-635	Self extinguishing
Flame Spread / NFPA-101	ASTM E-84	Class A
Tensile Strength	ASTM D-638	3,700 psi
Flexural Strength	ASTM D-790	4,700 psi
Compressive Strength	ASTM D-695	16,000 psi
Izod Impact (ft. Lb./in. notch)	ASTM D-256	0.50
Bond Strength to Concrete	ASTM D- 4541	400 psi substrate fails
Elevated Temperature	MIL D-3134	No slip or flow
Thermal Shock, 50 cycles of immersion in Chilled & boiling water	MIL F-52505	No cracking or loss of adhesion
UV Resistance	MIL F-52505	No chalking or loss of adhesion
Abrasion Resistance, CS-17 Wheel, Wgt. Loss, 1000 gm. Load, 1000 cycles	ASTM D-4060	24 mg.loss
VOC Content		0 g/l

### GUIDE SPECIFICATIONS

This product is part of the DUR-A-FLEX family of polymer systems. Please contact DUR-A-FLEX for complete three part guide specs.

### CLEANING

This product is considered to be a low maintenance flooring solution; however, certain textures and service environments require specific procedures. Please refer to the master Cleaning Guide on our website.

### MOISTURE CONCERNS

Please refer to the Floor Evaluation Flow Chart in the Contractor's Center of our website for a step-by-step process to determine the condition of the concrete.

### DRAWINGS AND DETAILS

Standard CAD drawings and details are available for covers, drains, breaches, transitions, etc. Please contact DUR-A-FLEX for actual drawings.

### CAUTION

**Follow the Hazardous Materials Identification System labeling guide for proper personal protective equipment to use when handling this product. Use only as directed. KEEP OUT OF REACH OF CHILDREN. Before using any Dur-A-Flex, Inc. product, be sure the Material Safety Data Sheet is read and understood.**

*Before using any DUR-A-FLEX, Inc. product be sure the Material Safety Data Sheet is read and understood.*

## **DUR-A-CHIP DECORATIVE EPOXY FLOORING**

**IMPORTANT!** Read these instructions carefully several days prior to starting your work. Seek answers to any questions you may have before you begin. DUR-A-FLEX, Inc. maintains a Technical Staff that will be glad to answer your questions and give you advice pertaining to your particular installation.

### **DUR-A-CHIP is applied by broadcast method.**

When recommended spread rates are followed, a double broadcast of either MICRO or MACRO decorative chip will produce a nominal 35 mil floor system. Surface finish can be smooth or slip resistant.

### **SURFACE PREPARATION**

Surface must be clean, sound, dry and free of all oil, grease, detergent film, sealers and/or curing compounds. A surface profile of 10 to 15 mils is appropriate for most applications. All paint should be removed unless it is a properly applied, totally de-glossed, high quality epoxy. Upper level rooms, like mechanical rooms, bathrooms, or wet process areas that have space below should receive ELAST-O-COAT seamless fluid applied membrane. Please refer to the DUR-A-FLEX Surface Preparation Guide on our website for detailed instructions.

### **MIXING AREA**

Select a convenient mix area and protect the surface from spillage by covering with a layer of cardboard and/or sheet of plastic. Be generous with the amount of space you allocate for this function. The more comfortably your mixer works, the less likely you are to have a "mix error". Make ready all necessary tools, mix and measure containers, etc. **DO NOT MIX ANY EPOXY UNTIL READY FOR IMMEDIATE USE.** Once hardener and resin are combined, it must be used without delay. Apply masking tape wherever coating is intended to stop. To obtain neat, straight, chip resistant edges at termination points and/or drains, a "keyed edge" must be installed.

### **PRE-PATCH**

Pre-patch badly eroded, spalled or cracked areas with the proper material: Use ELAST-O-COAT thickened with NO SAG 1 for moving joints and DUR-A-GLAZE #4 mixed with NO-SAG 2 or Flintshot for non-moving joints. **BE SURE TO LEAVE AS LITTLE EXCESS AS POSSIBLE AS IT WILL BE HIGHLIGHTED IN SUCCESSIVE STEPS.** Sanding or grinding pre-patch areas will help in hiding deviations.

### **PRIMING**

All surfaces must be primed with DUR-A-SHIELD, DUR-A-GLAZE WB or DUR-A-GLAZE #4 TIE-COAT II as soon as the surface has been prepared.

### **APPLICATION METHOD**

- A. Prepare the surface as outlined in the DUR-A-FLEX Surface Preparation Guide.
- B. Measure out 1/2 gallon of DUR-A-GARD OPF hardener and 1gallon of DUR-A-GARD resin. When combining, be sure to add the hardener first. Add the resin and scrape out the container. Be careful to pour both hardener and resin into the center of the mixing pail. Mix the blended epoxy with a slow speed power drill with a Jiffler type mixing blade for 2 minutes. **Always scrape the sides and bottom of the measuring bucket to assure thorough blending.**
- C. Apply the mixed DUR-A-GARD using a non-shed 18," 3/8 inch nap roller at 300 Sq Ft per gallon by the dip and roll method. Back roll with a quality, non-shed roller 18," 3/8 inch nap roller.
- D. Broadcast MICRO or MACRO decorative chip. While wearing spiked shoes, walk on the wet epoxy holding a 2-gallon container and broadcast the decorative chip until the floor appears dry (0.10 lbs per SF for macro and 0.15 lbs per SF for micro chips). Be sure to keep moving while throwing the chips UP into the air so it falls vertically onto the epoxy. Do not rush, as it may take 15 to 30 seconds for the chips to be absorbed by the epoxy. **IMPORTANT:** Do not "seed" the edge that will be joining the next section. Be sure to leave a "WET EDGE" (a 24" strip "unseeded" to permit overlapping when proceeding onto next section). Do not walk on the decorative chip with spiked shoes. Be sure to keep any impurities out of the chips such as broom bristles, debris, etc. Allow to cure.
- E. Sweep off the excess decorative chip using a stiff, clean, dry broom with synthetic bristles.
- F. Scrape the floor with a trowel or floor scraper. Sweep and vacuum the floor again.
- G. Measure out 1 part DUR-A-GLAZE #4 WATER CLEAR hardener and 2 parts DUR-A-GLAZE #4 resin and mix the blended epoxy for 2 minutes. Be sure to

follow the procedures outlined in step (B). Mix only what you can apply within 5 - 10 minutes.

- H. Apply the mixed DUR-A-GLAZE #4 WATER CLEAR at 200 Sq Ft per gallon with a flat squeegee and back roll with a quality 18", 3/8" non-shed roller.
- I. Broadcast MICRO or MACRO decorative chip. Follow procedures outlined in step (D) above. Allow to cure.
- J. Sweep off the excess decorative chip using a stiff, clean, dry broom with synthetic bristles.
- K. Scrape the floor with a trowel or floor scraper. Sweep and vacuum the floor again.
- L. Apply a coat of DUR-A-GLAZE #4 WATER CLEAR at 100 Sq Ft per gallon with a flat squeegee and back roll with a quality 18", 3/8" non-shed roller. Follow the same procedure for mixing as outlined in step (F). For anti-slip properties, back roll Aluminum Oxide #54 to #36 into grout coat.
- M. Apply Armor Top per Product Data Sheet instructions.

Remove all masking tape as you proceed, before it gets out of reach. Allow to cure.

***Before using any DUR-A-FLEX, Inc. product, be sure the Material Safety Data Sheet is read and understood***

**IMPORTANT:** Be sure to pour the hardener into the mixing bucket first, when working with the epoxy and vice versa when working with the urethane. Always scrape the sides and bottom of mixing container to assure thorough blending. USE SIGNS AND BARRIERS to keep traffic out of the area. Do not allow any water on coated surface for 24-48 hours. Chemical spillage must be prevented for approximately 5 days. NOTE: Use DUR-A-SOLVE or a lacquer thinner for clean up. Follow the Hazardous Materials Identification System labeling guide for proper personal protective equipment to use when handling this product. Use only as directed. KEEP OUT OF REACH OF CHILDREN.

**JOINT GUIDELINES**

Refer to the Joint Guidelines for complete details on our website.



**DUR-A-FLEX**  
INNOVATION FROM THE FLOOR UP

95 Goodwin Street, East Hartford, CT., 06108 (860) 528-9838

# Material Safety Data Sheet

Date Prepared 8/2/2010

## SECTION I - IDENTIFICATION

**IDENTITY (As Used on Label)** Dur-A-Gard Hardener: No Sag, Regular, OPF, Fast, Crete-Gard

**COMMON NAME** Amine Curative for Epoxy resin

HAZARD RATING 0 = Least  1 = Slight 2 = Moderate 3 = High 4 = Extreme	Health	3
	Flammability	1
	Reactivity	0
	Personal Protection	G

SECTION II - PRODUCT COMPONENTS	CAS.#	OSHA PEL	ACGIH TLV
---------------------------------	-------	----------	-----------

SECTION II - PRODUCT COMPONENTS	CAS.#	OSHA PEL	ACGIH TLV
Benzyl Alcohol	100-51-6	N.E. <sup>1</sup>	N.E.
3, Aminomethyl -3,5,5-Trimethyl	2855-13-2	N.E.	N.E.
1, 5 Pentanediamine, 2 Methyl	15520-10-2	N.E.	N.E.
N, Aminoethyl Piperazine	140-31-8	N.E.	N.E.
Diglycidyl Ether Bisphenol A Epoxy Resin	25085-99-8	N.E.	N.E.
Salicylic Acid	69-72-7	N.E.	N.E.
Polyoxypropylenediamine	9046-10-0	N.E.	N.E.
Amorphous Fumed Silica	7631-86-9	N.E.	N.E.
Propylene Glycol Monomethyl Ether	107-98-2	N.E.	N.E.
Nonyl Phenol	84852-15-3	N.E.	N.E.
Triphenyl Phosphite	101-02-0	N.E.	N.E.

<sup>1</sup>None Established

T.S.C.A. Status - O.K. on all above components.

**\*FOR SPILL, LEAK, FIRE, OR ACCIDENT, CALL CHEMTREC 24-HOUR EMERGENCY NUMBER 1-800-424-9300\***

## SECTION III - PHYSICAL/CHEMICAL CHARACTERISTICS

Boiling Point	250°F	Specific Gravity (H2O = 1)	< 1
Vapor Pressure (mm Hg)	12.6	Melting Point	N/A
Vapor Density (AIR = 1)	N/A	Evaporation rate (Butyl Acetate = 1)	0.7
Solubility in Water	Partially soluble.		
Appearance and Odor	Clear low viscosity liquid. Mild amine odor.		

## SECTION IV - FIRE and EXPLOSION HAZARD DATA

Flash Point (Closed Cup Method)	100°F	Flammable Limits	LEL	UEL
			N/A	N/A

Extinguishing Media Water spray, Foam, CO<sub>2</sub>, Dry Chemicals.

Special Firefighting Procedures

Wear full protective equipment including self-contained breathing apparatus.

Irritating and/or toxic gases may be generated by fire.

Unusual Fire and Explosion Hazards

Cool storage containers with water spray to prevent pressure build-up that may rupture the containers.

## SECTION V - REACTIVITY DATA

Stability	Unstable		Conditions to Avoid
	Stable	X	Keep containers closed when not in use.
Incompatibility (Materials to Avoid)	Strong oxidizers and acids.		
Hazardous Decomposition or Byproducts	By Fire - Carbon monoxide, Carbon dioxide, Nitrogen oxides.		
Hazardous Polymerization	May Occur		Conditions to Avoid
	Will Not Occur	X	Uncontrolled reaction with epoxy resins.

## SECTION VI - HEALTH HAZARD DATA

Route(s) of Entry:	Inhalation?	Skin?	Ingestion?
	YES	YES	YES

Signs and Symptoms of Exposure Irritation of skin.

Health Hazards (Acute and Chronic)

ACUTE - Irritation of skin and dermatitis.

CHRONIC - Repeated overexposure will cause severe skin irritation, dermatitis and sensitization. Sensitized persons may experience rapid irritation of skin upon exposure.

Persons with lung disorders or who are sensitized should not use this product.

Carcinogenicity:	NTP?	IARC Monographs?	OSHA Regulated?
	NO	NO	NO

Medical Conditions Generally Aggravated by Exposure

Allergy, skin disorders.

Emergency and First Aid Procedures

EYES - Flush with water, holding lids open for 15 minutes or more. Call physician for advice if necessary.

SKIN - PROMPTLY wash with soap and water. DO NOT wash with solvents. Seek medical advice if irritation develops or persists.

INHALATION - Move person to fresh air if effects occur. If needed, give oxygen or artificial respiration to improve breathing. Consult physician.

INGESTION - Get medical attention immediately. Never give liquids to an unconscious or convulsing person.

## SECTION VII - CONTROL MEASURES

Respiratory Protection (Specify Type)

Provide adequate exhaust ventilation; use a NIOSH approved respirator if PELs/TLVs are exceeded.

Ventilation	Local Exhaust	If needed.	Special	None known.
	Mechanical	Adequate exhaust ventilation must exhaust AWAY from applicator.		

Protective Gloves	Natural rubber or Neoprene.	Eye Protection	Splash goggles or face shield.
-------------------	-----------------------------	----------------	--------------------------------

Other Protective Clothing or Equipment

Use rubber apron, face shield and appropriate clothing to prevent contact with skin. Launder contaminated clothing before reuse. Discard contaminated leather shoes and canvas sneakers. Protective skin creams help cleaning with soap and water, gloves must still be worn. An eye wash station or an adequate supply of clean water must be available at work area.

Work/Hygienic Practices Enforce careful handling to prevent splashing. Wash thoroughly after use.

## SECTION VIII - PRECAUTIONS FOR SAFE HANDLING AND USE

Steps to be Taken in Case Material is Released or Spilled

Wear protective equipment to prevent exposure. Stop spill and dike to prevent spreading. Cover spill with absorbent materials and collect into containers. Clean contaminated area with detergent and water or a steam cleaner for best results.

Waste Disposal Method

Dispose in accordance with Federal, State and Local requirements.

Precautions to be Taken in Handling and Storing

Keep containers tightly closed when not in use.

Other Precautions NONE KNOWN.

Prepared by Samet Dy - Chemist

**PLEASE NOTE** "The above information is accurate to the best of our knowledge. However, since data, safety standards, and government regulations are subject to change and the conditions of handling and use, or misuse, are beyond our control, Dur-A-Flex, Inc. MAKES NO WARRANTY, EITHER EXPRESS OR IMPLIED, WITH RESPECT TO THE COMPLETENESS OR CONTINUING ACCURACY OF THE INFORMATION CONTAINED HEREIN AND DISCLAIMS ALL LIABILITY FOR RELIANCE THEREON. User should satisfy himself that he has all current data relevant to his particular use."



95 Goodwin Street, East Hartford, CT., 06108 (860) 528-9838

# Material Safety Data Sheet

Date Prepared 9/1/2008

<b>SECTION I - IDENTIFICATION</b>	HAZARD RATING 0 = Least 1 = Slight 2 = Moderate 3 = High 4 = Extreme	Health	1
		Flammability	1
		Reactivity	0
		Personal Protection	G
<b>IDENTITY (As Used on Label)</b>	<b>Dur-A-Gard Resin: all colors/Bio-Pruf®</b>		
<b>COMMON NAME</b>	Pigmented Epoxy Resin		

<b>SECTION II - PRODUCT COMPONENTS</b>	<b>CAS.#</b>	<b>OSHA PEL</b>	<b>ACGIH TLV</b>
Diglycidyl Ether Bisphenol A Epoxy Resin	25068-38-6	N.E. <sup>1</sup>	N.E.
Aliphatic Glycidyl Ether Diluent	68609-97-2	N.E.	N.E.
Titanium Dioxide	13463-67-7	15mg/m <sup>3</sup>	10mg/m <sup>3</sup>
Calcium Carbonate	1317-65-3	15mg/m <sup>3</sup>	10mg/m <sup>3</sup>
Aluminum Silicate	1332-58-7	15mg/m <sup>3</sup>	2mg/m <sup>3</sup>
Barium Sulfate <sup>2</sup>	7727-43-7	10mg/m <sup>3</sup>	10mg/m <sup>3</sup>
Inorganic Iron Oxides	1309-37-1	15mg/m <sup>3</sup>	10mg/m <sup>3</sup>
Chromium(III) Oxide Green(trivalent chromium) <sup>*3</sup>	1308-38-9	1mg/m <sup>3</sup>	0.5mg/m <sup>3</sup>

<sup>1</sup>Not Established

<sup>2</sup>Barium Sulfate is listed in SARA III, Part 372, Section 313.

<sup>\*3</sup>This product contains only 1-3ppm (0.0001%-0.0003%) leachable hexavalent chromium. Trivalent chromium is not specifically listed as a possible carcinogen. Only in Dark Green and Light Green pigmented systems.

T.S.C.A. Status - O.K. on all above components.

**\*FOR SPILL, LEAK, FIRE, OR ACCIDENT, CALL CHEMTREC 24-HOUR EMERGENCY NUMBER 1-800-424-9300\***

## SECTION III - PHYSICAL/CHEMICAL CHARACTERISTICS

Boiling Point	N/A	Specific Gravity (H2O = 1)	1.55
Vapor Pressure (mm Hg)	N/A	Melting Point	N/A
Vapor Density (AIR = 1)	N/A	Evaporation rate (Butyl Acetate = 1)	N/A
Volatile Organic Compounds (VOC)	0 g/L		
Solubility in Water	NONE		
Appearance and Odor	Pigmented viscous liquid. Mild characteristic odor.		

## SECTION IV - FIRE and EXPLOSION HAZARD DATA

Flash Point (Closed Cup Method)	485°F	Flammable Limits	LEL	UEL
			N/A	N/A

Extinguishing Media Water spray, Foam, CO<sub>2</sub>, Dry Chemicals.

Special Firefighting Procedures

Wear full protective equipment including self-contained breathing apparatus.

Unusual Fire and Explosion Hazards

Cool storage containers with water spray to prevent pressure build-up that may rupture the containers.

Combustion products may be toxic.

## SECTION V - REACTIVITY DATA

Stability	Unstable		Conditions to Avoid
	Stable	X	Excess heating over long periods of time degrades the resin.

Incompatibility (Materials to Avoid) Uncontrolled reaction with amines.

Hazardous Decomposition or Byproducts By Fire - Carbon monoxide, Carbon dioxide, Nitrogen oxides, Aldehydes.

Hazardous Polymerization	May Occur		Conditions to Avoid
	Will Not Occur	X	Uncontrolled reaction with amines.

**SECTION VI - HEALTH HAZARD DATA**

Route(s) of Entry:	Inhalation? YES	Skin? YES	Ingestion? YES
Signs and Symptoms of Exposure	Irritation of skin.		
Health Hazards (Acute and Chronic)			
ACUTE - Irritation of skin and dermatitis.			
CHRONIC - Repeated overexposure will cause severe skin irritation, dermatitis and sensitization. Sensitized persons may experience rapid irritation of skin upon exposure.			
Persons with lung disorders or who are sensitized should not use this product.			
Carcinogenicity:	NTP? NO	IARC Monographs? NO	OSHA Regulated? NO

Medical Conditions Generally Aggravated by Exposure  
Allergy, skin disorders.

Emergency and First Aid Procedures

EYES - Flush with water, holding lids open for 15 minutes or more. Call physician for advice if necessary.

SKIN - PROMPTLY wash with soap and water. DO NOT wash with solvents. Seek medical advice if irritation develops or persists.

INHALATION - Move person to fresh air if effects occur. If needed, give oxygen or artificial respiration to improve breathing. Consult physician.

INGESTION - Get medical attention immediately. Never give liquids to an unconscious or convulsing person.

**SECTION VII - CONTROL MEASURES**

Respiratory Protection (Specify Type)  
Provide adequate exhaust ventilation; use a NIOSH approved respirator if PELS/TLVS are exceeded.

Ventilation	Local Exhaust	If needed.	Special	None known.
	Mechanical	Adequate exhaust ventilation must exhaust AWAY from applicator.		

Protective Gloves Natural rubber or Neoprene. Eye Protection Splash goggles or face shield.

Other Protective Clothing or Equipment  
Use rubber apron, face shield and appropriate clothing to prevent contact with skin. Launder contaminated clothing before reuse. Discard contaminated leather shoes and canvas sneakers. Protective skin creams help cleaning with soap and water, gloves must still be worn. An eye wash station or an adequate supply of clean water must be available at work area.

Work/Hygienic Practices Enforce careful handling to prevent splashing. Wash thoroughly after use.

**SECTION VIII - PRECAUTIONS FOR SAFE HANDLING AND USE**

Steps to be Taken in Case Material is Released or Spilled  
Wear protective equipment to prevent exposure. Stop spill and dike to prevent spreading. Cover spill with absorbent materials and collect into containers. Clean contaminated area with detergent and water or a steam cleaner for best results.

Waste Disposal Method  
Dispose in accordance with Federal, State and Local requirements.

Precautions to be Taken in Handling and Storing  
Keep containers tightly closed when not in use.

Other Precautions NONE KNOWN.

Prepared by Samet Dy - Chemist

**PLEASE NOTE** "The above information is accurate to the best of our knowledge. However, since data, safety standards, and government regulations are subject to change and the conditions of handling and use, or misuse, are beyond our control, Dur-A-Flex, Inc. MAKES NO WARRANTY, EITHER EXPRESS OR IMPLIED, WITH RESPECT TO THE COMPLETENESS OR CONTINUING ACCURACY OF THE INFORMATION CONTAINED HEREIN AND DISCLAIMS ALL LIABILITY FOR RELIANCE THEREON. User should satisfy himself that he has all current data relevant to his particular use."



95 Goodwin Street, East Hartford, CT., 06108 (860) 528-9838

# Material Safety Data Sheet

Date Prepared 8/2/2010

<b>SECTION I - IDENTIFICATION</b>	HAZARD RATING	Health	3
	0 = Least	Flammability	1
	1 = Slight 2 = Moderate 3 = High 4 = Extreme	Reactivity	0
		Personal Protection	G
IDENTITY (As Used on Label)	<b>Dur-A-Glaze #4 Hardener: Regular, Fast, Cold Cure, CR4, Damp-Primer, Water Clear</b>		
COMMON NAME	Epoxy Resin Curatives		

SECTION II - PRODUCT COMPONENTS	CAS.#	OSHA PEL	ACGIH TLV
Benzyl Alcohol	100-51-6	N.E. <sup>1</sup>	N.E.
3, Aminomethyl -3,5,5-Trimethyl	2855-13-2	N.E.	N.E.
1, 5 Pentanediamine, 2 Methyl	15520-10-2	N.E.	N.E.
N, Aminoethyl Piperazine	140-31-8	N.E.	N.E.
Diglycidyl Ether Bisphenol A Epoxy Resin	25085-99-8	N.E.	N.E.
Salicylic Acid	69-72-7	N.E.	N.E.
1, 5 Pentanediamine, 2 Methyl	15520-10-2	N.E.	N.E.
Benzene-1,3-Dimethaneamine	1477-550	N.E.	N.E.
Phenol	108-95-2	N.E.	N.E.
Triphenyl phosphite	101-02-0	N.E.	N.E.

<sup>1</sup>None Established

T.S.C.A. Status - O.K. on all above components.  
**\*FOR SPILL, LEAK, FIRE, OR ACCIDENT, CALL CHEMTREC 24-HOUR EMERGENCY NUMBER 1-800-424-9300\***

### SECTION III - PHYSICAL/CHEMICAL CHARACTERISTICS

Boiling Point	485°F	Specific Gravity (H2O = 1)	<1
Vapor Pressure (mm Hg)	0.02	Melting Point	N/A
Vapor Density (AIR = 1)	N/A	Evaporation rate (Butyl Acetate = 1)	N/A
Volatile Organic Compounds (VOC)	0 g/l		
Solubility in Water	Partially soluble.		
Appearance and Odor	Pale yellow colored liquid. Amine odor.		

### SECTION IV - FIRE and EXPLOSION HAZARD DATA

Flash Point (Closed Cup Method)	220°F	Flammable Limits	LEL	UEL
			N/A	N/A
Extinguishing Media	Dry chemicals, carbon dioxide, foam, water spray.			
Special Firefighting Procedures	Firefighters should wear full emergency equipment with self-contained breathing apparatus. Irritating gases may be generated by fire.			
Unusual Fire and Explosion Hazards	Cool exposed containers with cold water spray to prevent pressure buildup that may rupture the containers.			

### SECTION V - REACTIVITY DATA

Stability	Unstable		Conditions to Avoid
	Stable	X	Keep container closed when not in use.
Incompatibility (Materials to Avoid)	Strong oxidizers and acids.		
Hazardous Decomposition or Byproducts	By Fire- carbon monoxide, carbon dioxide, aldehydes, nitrogen.		
Hazardous Polymerization	May Occur		Conditions to Avoid Uncontrolled reaction with epoxy resins. Avoid breathing fumes generated by hardener and epoxy mixture when not used within established pot life.
	Will Not Occur	X	

## SECTION VI - HEALTH HAZARD DATA

Route(s) of Entry:	Inhalation?	Skin?	Ingestion?
	YES	YES	YES

Signs and Symptoms of Exposure Irritation on skin.

Health Hazards (Acute and Chronic)

Note: Persons with lung disorders or who are sensitized should not use this product.

ACUTE - Irritation on skin and dermatitis.

CHRONIC - Repeated overexposure will cause severe skin irritation, dermatitis and sensitization.

Sensitized persons may experience rapid irritation of skin upon exposure.

Carcinogenicity:	NTP?	IARC Monographs?	OSHA Regulated?
	NO	NO	NO

Medical Conditions Generally Aggravated by Exposure

Allergy, skin disorders.

Emergency and First Aid Procedures

EYES - Flush with water, holding lids open for 15 minutes or more. Call physician for advice if necessary.

SKIN - PROMPTLY wash with soap and water. DO NOT wash with solvents. Seek medical advice if irritation develops or persists.

INHALATION - Move person to fresh air if effects occur. If needed, give oxygen or artificial respiration to improve breathing. Consult physician.

INGESTION - Get medical attention immediately. Never give liquids to an unconscious or convulsing person.

## SECTION VII - CONTROL MEASURES

Respiratory Protection (Specify Type)

Provide adequate exhaust ventilation; use a NIOSH approved respirator if PELs/TLVs are exceeded.

Ventilation	Local Exhaust	If needed.	Special	None known.
	Mechanical	Adequate exhaust ventilation must exhaust AWAY from applicator.		

Protective Gloves	Natural or Neoprene gloves.	Eye Protection	Splash goggles or face shield.
-------------------	-----------------------------	----------------	--------------------------------

Other Protective Clothing or Equipment

Use rubber apron, face shield and appropriate clothing to prevent contact with skin. Launder contaminated clothing before reuse. Discard contaminated leather shoes and canvas sneakers. Protective skin creams help cleaning with soap and water, gloves must be still be worn. An eye wash station or an adequate supply of clean water must be available at work area.

Work/Hygienic Practices Enforce careful handling to prevent splashing. Wash thoroughly after use.

## SECTION VIII - PRECAUTIONS FOR SAFE HANDLING AND USE

Steps to be Taken in Case Material is Released or Spilled

Wear protective equipment to prevent exposure. Stop spill and dike to prevent spreading. Cover spill with absorbent materials and collect into containers. Clean contaminated area with detergent and water or a steam cleaner for best results.

Waste Disposal Method

Dispose in accordance with Federal, State, and Local requirements.

Precautions to be Taken in Handling and Storing

Keep containers tightly closed when not in use.

Other Precautions NONE KNOWN.

Prepared by Samet Dy - Chemist

**PLEASE** "The above information is accurate to the best of our knowledge. However, since data, safety standards, and government regulations are subject to change and the conditions of handling and use, or misuse, are beyond our control, Dur-A-Flex, Inc. MAKES NO WARRANTY, EITHER EXPRESS OR IMPLIED, WITH RESPECT TO THE COMPLETENESS OR CONTINUING ACCURACY OF THE INFORMATION CONTAINED HEREIN AND DISCLAIMS ALL LIABILITY FOR RELIANCE THEREON. User should satisfy himself that he has all current data relevant to his particular use."

**NOTE**



**DUR-A-FLEX**  
INNOVATION FROM THE FLOOR UP

95 Goodwin Street, East Hartford, CT., 06108 (860) 528-9838

# Material Safety Data Sheet

Date Prepared 8/2/2010

<b>SECTION I - IDENTIFICATION</b>	HAZARD RATING 0 = Least 1 = Slight 2 = Moderate 3 = High 4 = Extreme	Health	1
		Flammability	1
		Reactivity	0
		Personal Protection	G
IDENTITY (As Used on Label) <b>Dur-A-Glaze #4 RESIN/ Bio-Pruf®</b>			
COMMON NAME Epoxy Resin			

SECTION II - PRODUCT COMPONENTS	CAS.#	OSHA PEL	ACGIH TLV
Diglycidyl Ether Bisphenol A Epoxy Resin	25085-99-8	N.E. <sup>1</sup>	N.E.
Aliphatic Glycidyl Ether Diluent	68609-97-2	N.E.	N.E.
Film Additives	Proprietary <sup>2</sup>	N.E.	N.E.

<sup>1</sup>Not Established

<sup>2</sup>The manufacturer of these component states that they will provide additional information to a health professional in the event of an emergency.

T.S.C.A. Status - O.K. on all above components.

**\*FOR SPILL, LEAK, FIRE, OR ACCIDENT, CALL CHEMTREC 24-HOUR EMERGENCY NUMBER 1-800-424-9300\***

### SECTION III - PHYSICAL/CHEMICAL CHARACTERISTICS

Boiling Point	N/A	Specific Gravity (H2O = 1)	>1
Vapor Pressure (mm Hg)	N/A	Melting Point	N/A
Vapor Density (AIR = 1)	N/A	Evaporation rate (Butyl Acetate = 1)	N/A
Volatile Organic Compounds (VOC)	0 g/L		
Solubility in Water	None		
Appearance and Odor	Viscous liquid. Mild characteristic odor.		

### SECTION IV - FIRE and EXPLOSION HAZARD DATA

Flash Point (Closed Cup Method)	485°F	Flammable Limits	LEL	UEL
			N/A	N/A

Extinguishing Media Foam, CO<sub>2</sub>, Dry Chemical, Water Spray.

Special Firefighting Procedures

Firefighters should wear full emergency equipment with self-contained breathing apparatus.

Unusual Fire and Explosion Hazards

Cool fire - exposed containers with cold water spray to prevent pressure build - up that may rupture the container. Combustion products may be toxic.

### SECTION V - REACTIVITY DATA

Stability	Unstable		Conditions to Avoid
	Stable	X	Excess heating over long periods of time degrades the resin.

Incompatibility (Materials to Avoid) Uncontrolled reaction with amines.

Hazardous Decomposition or Byproducts Fire- Carbon Monoxide, Carbon Dioxide, Nitrogen Oxide, Aldehydes.

Hazardous Polymerization	May Occur		Conditions to Avoid
	Will Not Occur	X	Uncontrolled reaction with amines.

**SECTION VI - HEALTH HAZARD DATA**

Route(s) of Entry:	Inhalation? YES	Skin? YES	Ingestion? YES
Signs and Symptoms of Exposure	Irritation on skin.		
Health Hazards (Acute and Chronic)			
ACUTE - Irritation on skin and dermatitis.			
CHRONIC - Repeated overexposure will cause severe skin irritation, dermatitis and sensitization. Sensitized persons may experience rapid irritation of skin upon exposure.			

Carcinogenicity:	NTP? NO	IARC Monographs? NO	OSHA Regulated? NO
------------------	------------	------------------------	-----------------------

Medical Conditions Generally Aggravated by Exposure  
Allergy, skin disorders.

Emergency and First Aid Procedures

EYES - Flush with water, holding lids open for 15 minutes or more. Call physician for advice if necessary.

SKIN - PROMPTLY wash with soap and water. DO NOT wash with solvents. Seek medical advice if irritation develops or persists.

INHALATION - Move person to fresh air if effects occur. If needed, give oxygen or artificial respiration to improve breathing. Consult physician.

INGESTION - Get medical attention immediately. Never give liquids to an unconscious or convulsing person.

Note: Persons with lung disorders or who are sensitized should not use this product.

**SECTION VII - CONTROL MEASURES**

Respiratory Protection (Specify Type)  
Provide adequate exhaust ventilation; use a NIOSH - approved respirator if PELS/TLVS are exceeded.

Ventilation	Local Exhaust	If needed.	Special	None known.
	Mechanical	Adequate exhaust ventilation must exhaust AWAY from applicator.		

Protective Gloves	Natural or Neoprene gloves.	Eye Protection	Splash goggles or face shield.
-------------------	-----------------------------	----------------	--------------------------------

Other Protective Clothing or Equipment

Use rubber apron, face shield and appropriate clothing to prevent contact with skin. Launder contaminated clothing before reuse. Discard contaminated leather shoes and canvas sneakers. Protective skin creams help cleaning with soap and water, gloves must be still be worn. An eye wash station or an adequate supply of clean water must be available at work area.

Work/Hygienic Practices Enforce careful handling to prevent splashing. Wash thoroughly after use.

**SECTION VIII - PRECAUTIONS FOR SAFE HANDLING AND USE**

Steps to be Taken in Case Material is Released or Spilled

Wear protective equipment to prevent exposure. Stop spill and dike to prevent spreading. Cover spill with absorbent materials and collect into containers. Clean contaminated area with detergent and water or a steam cleaner for best results.

Waste Disposal Method

Dispose in accordance with Federal, State, and Local requirements.

Precautions to be Taken in Handling and Storing

Keep containers tightly closed when not in use.

Other Precautions NONE KNOWN.

Prepared by Samet Dy - Chemist

**PLEASE NOTE** "The above information is accurate to the best of our knowledge. However, since data, safety standards, and government regulations are subject to change and the conditions of handling and use, or misuse, are beyond our control, Dur-A-Flex, Inc. MAKES NO WARRANTY, EITHER EXPRESS OR IMPLIED, WITH RESPECT TO THE COMPLETENESS OR CONTINUING ACCURACY OF THE INFORMATION CONTAINED HEREIN AND DISCLAIMS ALL LIABILITY FOR RELIANCE THEREON. User should satisfy himself that he has all current data relevant to his particular use."



**DUR-A-FLEX**  
INNOVATION FROM THE FLOOR UP

95 Goodwin Street, East Hartford, CT., 06108 (860) 528-9838

# Material Safety Data Sheet

Date Prepared 8/2/2010

## SECTION I - IDENTIFICATION

IDENTITY (As Used on Label) **Dur-A-Glaze #4 WB Primer-Sealer Hardener**

COMMON NAME Emulsified Amine Curative

### HAZARD RATING

0 = Least  
1 = Slight  
2 = Moderate  
3 = High  
4 = Extreme

Health

3

Flammability

1

Reactivity

0

Personal Protection

G

## SECTION II - PRODUCT COMPONENTS

	CAS.#	OSHA PEL	ACGIH TLV
Water	7732-18-5	N.E. <sup>1</sup>	N.E.
Polyamine Curative	Proprietary <sup>2</sup>	N.E.	N.E.
Modified Epoxy Resin Adhesion Promotor	Proprietary	N.E.	N.E.

<sup>1</sup>None Established

<sup>2</sup>The manufacturer of the component states that they will provide additional information to a health professional in the event of a medical emergency.

T.S.C.A. Status - O.K. on all above components.

**\*FOR SPILL, LEAK, FIRE, OR ACCIDENT, CALL CHEMTREC 24-HOUR EMERGENCY NUMBER 1-800-424-9300\***

## SECTION III - PHYSICAL/CHEMICAL CHARACTERISTICS

Boiling Point	>400°F	Specific Gravity (H2O = 1)	1.07
Vapor Pressure (mm Hg)	not known	Melting Point	N/A
Vapor Density (AIR = 1)	not known	Evaporation rate (Butyl Acetate = 1)	not known

Volatile Organic Compounds (VOC) = < 2 grams/liter

Solubility in Water Soluble

Appearance and Odor Pale yellow viscous liquid. Mild ester-like odor.

## SECTION IV - FIRE and EXPLOSION HAZARD DATA

Flash Point (Closed Cup Method)	212°F	Flammable Limits	LEL	UEL
			N/A	N/A

Extinguishing Media Water spray, Foam, CO<sub>2</sub>, Dry Chemicals.

Special Firefighting Procedures

Wear full protective equipment including self-contained breathing apparatus.

Unusual Fire and Explosion Hazards

Cool storage containers with water spray to prevent pressure build-up that may rupture the containers.

Combustion products may be toxic.

## SECTION V - REACTIVITY DATA

Stability	Unstable		Conditions to Avoid
	Stable	X	None known

Incompatibility (Materials to Avoid) None known

Hazardous Decomposition or Byproducts By Fire - Carbon monoxide, Carbon dioxide, Nitrogen oxides.

Hazardous Polymerization	May Occur		Conditions to Avoid
	Will Not Occur	X	None known.

**SECTION VI - HEALTH HAZARD DATA**

Route(s) of Entry:	Inhalation?	Skin?	Ingestion?
	YES	YES	YES

Signs and Symptoms of Exposure      Irritation of skin.

Health Hazards (Acute and Chronic)

ACUTE - Irritation of skin and dermatitis.

CHRONIC - Repeated overexposure will cause severe skin irritation, dermatitis and sensitization. Sensitized persons may experience rapid irritation of skin upon exposure.

Persons with lung disorders or who are sensitized should not use this product.

Carcinogenicity:	NTP?	IARC Monographs?	OSHA Regulated?
	NO	NO	NO

Medical Conditions Generally Aggravated by Exposure

Allergy, skin disorders

Emergency and First Aid Procedures

EYES - Flush with water, holding lids open for 15 minutes or more. Call physician for advice if necessary.

SKIN - PROMPTLY wash with soap and water. DO NOT wash with solvents. Seek medical advice if irritation develops or persists.

INHALATION - Move person to fresh air if effects occur. If needed, give oxygen or artificial respiration to improve breathing. Consult physician.

INGESTION - Get medical attention immediately. Never give liquids to an unconscious or convulsing person.

**SECTION VII - CONTROL MEASURES**

Respiratory Protection (Specify Type)

Provide adequate exhaust ventilation; use a NIOSH approved respirator if PELs/TLVs are exceeded.

Ventilation	Local Exhaust	If needed.	Special	None known.
	Mechanical	Adequate exhaust ventilation must exhaust AWAY from applicator.		

Protective Gloves	Natural rubber or Neoprene.	Eye Protection	Splash goggles or face shield.
-------------------	-----------------------------	----------------	--------------------------------

Other Protective Clothing or Equipment

Use rubber apron, face shield and appropriate clothing to prevent contact with skin. Launder contaminated clothing before reuse. Discard contaminated leather shoes and canvas sneakers. Protective skin creams help cleaning with soap and water, but gloves must still be worn. An eye wash station or an adequate supply of clean water must be available at work area.

Work/Hygienic Practices      Enforce careful handling to prevent splashing. Wash thoroughly after use.

**SECTION VIII - PRECAUTIONS FOR SAFE HANDLING AND USE**

Steps to be Taken in Case Material is Released or Spilled

Wear protective equipment to prevent exposure. Stop spill and dike to prevent spreading. Cover spill with absorbent materials and collect into containers. Clean contaminated area with detergent and water or a steam cleaner for best results.

Waste Disposal Method

Dispose in accordance with Federal, State and Local requirements.

Precautions to be Taken in Handling and Storing

Keep containers tightly closed when not in use.

Other Precautions      NONE KNOWN.

Prepared by      Samet Dy - Chemist

**PLEASE NOTE** "The above information is accurate to the best of our knowledge. However, since data, safety standards, and government regulations are subject to change and the conditions of handling and use, or misuse, are beyond our control, Dur-A-Flex, Inc. MAKES NO WARRANTY, EITHER EXPRESS OR IMPLIED, WITH RESPECT TO THE COMPLETENESS OR CONTINUING ACCURACY OF THE INFORMATION CONTAINED HEREIN AND DISCLAIMS ALL LIABILITY FOR RELIANCE THEREON. User should satisfy himself that he has all current data relevant to his particular use."



**DUR-A-FLEX**  
INNOVATION FROM THE FLOOR UP

95 Goodwin Street, East Hartford, CT., 06108 (860) 528-9838

# Material Safety Data Sheet

Date Prepared 8/2/2010

<b>SECTION I - IDENTIFICATION</b>	<b>HAZARD RATING</b> 0 = Least 1 = Slight 2 = Moderate 3 = High 4 = Extreme	Health	1
		Flammability	0
		Reactivity	0
		Personal Protection	A

**IDENTITY (As Used on Label)** Dur-A-Chips/ Cryl-A-Chips

**COMMON NAME** Pigmented Vinyl Flakes

<b>SECTION II - PRODUCT COMPONENTS</b>	<b>CAS.#</b>	<b>OSHA PEL</b>	<b>ACGIH TLV</b>
Ethylene Glycol	107-21-1	NE <sup>1</sup>	50ppm

<sup>1</sup>None Established

T.S.C.A. Status - O.K. on all components

**\*FOR SPILL, LEAK, FIRE, OR ACCIDENT, CALL CHEMTREC 24-HOUR EMERGENCY NUMBER 1-800-424-9300\***

## SECTION III - PHYSICAL/CHEMICAL CHARACTERISTICS

Boiling Point	N/A	Specific Gravity (H <sub>2</sub> O = 1)	2.5
Vapor Pressure (mm Hg)	N/A	Melting Point	N/A
Vapor Density (AIR = 1)	N/A	Evaporation rate (Butyl Acetate = 1)	N/A
Volatile Organic Compounds (VOC) = Zero grams/liter			
Solubility in Water	Insoluble		
Appearance and Odor	Various colored flakes.		

## SECTION IV - FIRE and EXPLOSION HAZARD DATA

Flash Point (Closed Cup Method)	N/A	Flammable Limits	LEL	UEL
			N/A	N/A
Extinguishing Media	Water or carbon dioxide			
Special Firefighting Procedures	Use respiratory masks to remove smoke and organic vapors.			
Unusual Fire and Explosion Hazards	When polymer burns, water, carbon dioxide, carbon monoxide and smoke are produced.			

## SECTION V - REACTIVITY DATA

Stability	Unstable	X	Conditions to Avoid
	Stable		Sulfuric acid and alkali materials .
Incompatibility (Materials to Avoid)	None known		
Hazardous Decomposition or Byproducts	Upon burning - acetic acid, acetaldehyde, carbon dioxide.		
Hazardous Polymerization	May Occur	X	Conditions to Avoid
	Will Not Occur		None known

## SECTION VI - HEALTH HAZARD DATA

Route(s) of Entry:	Inhalation?	Skin?	Ingestion?
	Yes	No	Possible

Signs and Symptoms of Exposure      Bronchial irritation.

### Health Hazards (Acute and Chronic)

No toxic effects have been noted from inhalation or ingestion in animals with exposure. Human health effects of overexposure may include a respiratory irritation with cough and shortness of breath. Individuals with pre-existing lung diseases may react more to over-exposure.

Carcinogenicity:	NTP?	IARC Monographs?	OSHA Regulated?
	No	No	No

### Medical Conditions Generally Aggravated by Exposure

May aggravate pre-existing respiratory conditions.

### Emergency and First Aid Procedures

Wash dust from the skin with soap and water. Flush out eyes with generous amounts of water for at least 15 minutes. See a physician if necessary.

## SECTION VII - CONTROL MEASURES

### Respiratory Protection (Specify Type)

Provide adequate exhaust ventilation; use a NIOSH approved respirator if PELs/TLVs are exceeded.

Ventilation	Local Exhaust	Use when needed.	Special	None
	Mechanical	Not usually required.		

Protective Gloves	Not usually required.	Eye Protection	Safety glasses.
-------------------	-----------------------	----------------	-----------------

### Other Protective Clothing or Equipment

Use a dust mask in a dusty environment.

Work/Hygienic Practices      Nothing unusual. Avoid dust.

## SECTION VIII - PRECAUTIONS FOR SAFE HANDLING AND USE

### Steps to be Taken in Case Material is Released or Spilled

Not a RCRA listed hazardous waste. Sweep up and/or shovel or use a vacuum to clean up spillage. Deposit into covered container for disposal.

### Waste Disposal Method

Dispose of according to Federal, State, or local regulations. If approved, remove to land disposal area.

### Precautions to be Taken in Handling and Storing

In case of skin contact, the compound is not likely to be hazardous but cleaning the skin after use is advisable.

Other Precautions      None known

Prepared by      Samet Dy - Urethane Chemist

**PLEASE NOTE** "The above information is accurate to the best of our knowledge. However, since data, safety standards, and government regulations are subject to change and the conditions of handling and use, or misuse, are beyond our control, Dur-A-Flex, Inc. MAKES NO WARRANTY, EITHER EXPRESS OR IMPLIED, WITH RESPECT TO THE COMPLETENESS OR CONTINUING ACCURACY OF THE INFORMATION CONTAINED HEREIN AND DISCLAIMS ALL LIABILITY FOR RELIANCE THEREON. User should satisfy himself that he has all current data relevant to his particular use."



**DUR-A-FLEX**  
INNOVATION FROM THE FLOOR UP

95 Goodwin Street, East Hartford, CT., 06108 (860) 528-9838

# Material Safety Data Sheet

Date Prepared 12/17/2010

## SECTION I - IDENTIFICATION

IDENTITY (As Used on Label) **Armor Top Grit**

COMMON NAME **WHITE ALUMINUM OXIDE**

HAZARD RATING

0 = Least  
1 = Slight  
2 = Moderate  
3 = High  
4 = Extreme

Health	0
Flammability	0
Reactivity	0
Personal Protection	G

## SECTION II - PRODUCT COMPONENTS

	CAS.#	OSHA PEL	ACGIH TLV
Aluminum Oxide	1344-28-1	5 mg/m <sup>3</sup> (resp)	10 mg/m <sup>3</sup>

Other Oxides (Total) (SiO<sub>2</sub>+Fe<sub>2</sub>O<sub>3</sub>+Na<sub>2</sub>O+MgO+TiO<sub>2</sub>)=1%

T.S.C.A. Status - O.K. on above component.

**\*FOR SPILL, LEAK, FIRE, OR ACCIDENT, CALL CHEMTREC 24-HOUR EMERGENCY NUMBER 1-800-424-9300\***

## SECTION III - PHYSICAL/CHEMICAL CHARACTERISTICS

Boiling Point	N/A	Specific Gravity (H <sub>2</sub> O = 1)	3.95
Vapor Pressure (mm Hg)	N/A	Melting Point	2070
Vapor Density (AIR = 1)	N/A	Evaporation rate (Butyl Acetate = 1)	N/A

Volatile Organic Compounds (VOC) = Zero grams/liter

Solubility in Water **INSOLUBLE**

Appearance and Odor **Granular, White, Odorless**

## SECTION IV - FIRE and EXPLOSION HAZARD DATA

Flash Point (Closed Cup Method)	N/A	Flammable Limits	LEL	UEL
			N/A	N/A

Extinguishing Media **N/A**

Special Firefighting Procedures

None Known.

Unusual Fire and Explosion Hazards

None Known.

## SECTION V - REACTIVITY DATA

Stability	Unstable		Conditions to Avoid
	Stable	X	

Incompatibility (Materials to Avoid) **None known.**

Hazardous Decomposition or Byproducts **None Known.**

Hazardous Polymerization	May Occur		Conditions to Avoid
	Will Not Occur	X	

**SECTION VI - HEALTH HAZARD DATA**

Route(s) of Entry:	Inhalation?	Skin?	Ingestion?
	Yes		Eyes

Signs and Symptoms of Exposure	Temporary Inhalation Discomfort.
--------------------------------	----------------------------------

Health Hazards (Acute and Chronic)

ACUTE - None known other than possible temporary discomfort due to inhalation of dust concentration.

CHRONIC - Potential chronic respiratory distress/irritation. Can aggravate pre-existing lung conditions.

Carcinogenicity:	NTP?	IARC Monographs?	OSHA Regulated?
	NO	NO	NO

Medical Conditions Generally Aggravated by Exposure  
None Known.

Emergency and First Aid Procedures

EYES - hold eyes apart and flush with clean water for 15 minutes. If irritation or redness develops and persists seek medical attention.

INHALATION - For inhalation discomfort move person to fresh air.

**SECTION VII - CONTROL MEASURES**

Respiratory Protection (Specify Type)

Provide adequate exhaust ventilation; use a NIOSH - approved respirator if PELS/TLVS are exceeded.

Ventilation	Local Exhaust	If necessary.	Special	None Known
	Mechanical	Adequate for dusty environments		

Protective Gloves	Wear gloves	Eye Protection	Safety goggles, do not wear contact lenses.
-------------------	-------------	----------------	---

Other Protective Clothing or Equipment

NONE KNOWN.

Work/Hygienic Practices Avoid unnecessary formation of dust.

**SECTION VIII - PRECAUTIONS FOR SAFE HANDLING AND USE**

Steps to be Taken in Case Material is Released or Spilled

Non - Skid Grit may be swept or vacuumed for normal disposal.

Waste Disposal Method

Non - Skid Grit is not a hazardous waste under U.S. Federal RCRA regulations.

Precautions to be Taken in Handling and Storing

Same as given in Section VII (ventilation, gloves, and goggles.)

Other Precautions Dry powders can build static charges when subjected to friction.

Prepared by William H. Greider, Jr. Technical Director

**PLEASE  
NOTE**

"The above information is accurate to the best of our knowledge. However, since data, safety standards, and government regulations are subject to change and the conditions of handling and use, or misuse, are beyond our control, Dur-A-Flex, Inc. MAKES NO WARRANTY, EITHER EXPRESS OR IMPLIED, WITH RESPECT TO THE COMPLETENESS OR CONTINUING ACCURACY OF THE INFORMATION CONTAINED HEREIN AND use."



95 Goodwin Street, East Hartford, CT., 06108 (860) 528-9838

# Material Safety Data Sheet

Date Prepared 12/17/2010

## SECTION I - IDENTIFICATION

**IDENTITY (As Used on Label)** **Armor Top Resin**  
**COMMON NAME** Blocked Cycloaliphatic Diamine

HAZARD RATING 0 = Least 1 = Slight 2 = Moderate 3 = High 4 = Extreme	Health	3
	Flammability	1
	Reactivity	0
	Personal Protection	G

## SECTION II - PRODUCT COMPONENTS

	CAS.#	OSHA PEL	ACGIH TLV
Blocked Cycloaliphatic Diamine	Proprietary <sup>2</sup>	N.E. <sup>1</sup>	N.E.

<sup>1</sup>None Established

<sup>2</sup>The manufacturer of the component states that they will provide additional information to a health professional in the event of a medical emergency.

T.S.C.A. Status - O.K. on all above components.

**\*FOR SPILL, LEAK, FIRE, OR ACCIDENT, CALL CHEMTREC 24-HOUR EMERGENCY NUMBER 1-800-424-9300\***

## SECTION III - PHYSICAL/CHEMICAL CHARACTERISTICS

Boiling Point	N.E.	Specific Gravity (H <sub>2</sub> O = 1)	0.8-0.9
Vapor Pressure (mm Hg)	N.E.	Melting Point	N/A
Vapor Density (AIR = 1)	N/A	Evaporation rate (Butyl Acetate = 1)	N/A

Volatiles Organic Compounds = Zero grams/liter

Solubility in Water Minimal, Reacts slowly with water

Appearance and Odor Pale yellow colored liquid. Amine odor.

## SECTION IV - FIRE and EXPLOSION HAZARD DATA

Flash Point (Closed Cup Method)	171°F	Flammable Limits	LEL	UEL
			N/A	N/A

Extinguishing Media Dry chemicals, carbon dioxide, foam, water spray.

Special Firefighting Procedures

Firefighters should wear full emergency equipment with self-contained breathing apparatus. Irritating gases may be generated by fire.

Cool exposed containers with cold water spray to prevent pressure buildup that may rupture the containers.

## SECTION V - REACTIVITY DATA

Stability	Unstable		Conditions to Avoid
	Stable	X	Keep container closed when not in use, protect from moisture.
Incompatibility (Materials to Avoid)		Strong oxidizers, alkaline materials and acids. Avoid moisture prior to use	
Hazardous Decomposition or Byproducts		By Fire- carbon monoxide, carbon dioxide, aldehydes, nitrogen.	
Hazardous Polymerization	May Occur		Conditions to Avoid Decomposition products from hydrolysis in water isophorone diamine and isobutylaldehyde
	Will Not Occur	X	

## SECTION VI - HEALTH HAZARD DATA

Route(s) of Entry:	Inhalation?	Skin?	Ingestion?
	YES	YES	YES

Signs and Symptoms of Exposure      Irritation on skin.

Health Hazards (Acute and Chronic)      Note: Persons with lung disorders or who are sensitized should not use this product.

ACUTE - Irritation on skin and dermatitis. Corrosive

CHRONIC - Repeated overexposure will cause severe skin irritation, dermatitis and sensitization.

Sensitized persons may experience rapid irritation of skin upon exposure.

Carcinogenicity:	NTP?	IARC Monographs?	OSHA Regulated?
	NO	NO	NO

Medical Conditions Generally Aggravated by Exposure  
Allergy, skin disorders.

Emergency and First Aid Procedures

EYES - **CORROSIVE**: Flush with water, holding lids open for 15 minutes or more. Call physician for advice if necessary.

SKIN - **CORROSIVE**; PROMPTLY wash with soap and water. DO NOT wash with solvents. Seek medical advice if irritation develops or persists.

INHALATION - Move person to fresh air if effects occur. If needed, give oxygen or artificial respiration to improve breathing. Consult physician.

INGESTION - Get medical attention immediately. Never give liquids to an unconscious or convulsing person.

## SECTION VII - CONTROL MEASURES

Respiratory Protection (Specify Type)

Provide adequate exhaust ventilation; use a NIOSH - approved respirator if PELs/TLVs are exceeded.

Ventilation	Local Exhaust	If needed.	Special	None known.
	Mechanical	Adequate exhaust ventilation must exhaust AWAY from applicator.		

Protective Gloves	Natural or Neoprene gloves.	Eye Protection	Splash goggles or face shield.
-------------------	-----------------------------	----------------	--------------------------------

Other Protective Clothing or Equipment

Use rubber apron, face shield and appropriate clothing to prevent contact with skin. Launder contaminated clothing before reuse. Protective skin creams help cleaning with soap and water, gloves must still be worn. An eye wash station or an adequate supply of clean water must be available at work area.

Work/Hygienic Practices      Enforce careful handling to prevent splashing. Wash thoroughly after use.

## SECTION VIII - PRECAUTIONS FOR SAFE HANDLING AND USE

Steps to be Taken in Case Material is Released or Spilled

Wear protective equipment to prevent exposure. Stop spill and dike to prevent spreading. Cover spill with absorbent materials and collect into containers. Clean contaminated area with detergent and water or a steam cleaner for best results.

Waste Disposal Method

Dispose in accordance with Federal, State, and Local requirements.

Precautions to be Taken in Handling and Storing

Keep containers tightly closed when not in use.

Other Precautions      NONE KNOWN.

Prepared by      William H. Greider, Jr. Technical Director

**PLEASE NOTE** "The above information is accurate to the best of our knowledge. However, since data, safety standards, and government regulations are subject to change and the conditions of handling and use, or misuse, are beyond our control, Dur-A-Flex, Inc. MAKES NO WARRANTY, EITHER EXPRESS OR IMPLIED, WITH RESPECT TO THE COMPLETENESS OR CONTINUING ACCURACY OF THE INFORMATION CONTAINED HEREIN AND DISCLAIMS ALL LIABILITY FOR RELIANCE THEREON. User should satisfy himself that he has all current data relevant to his particular use."



95 Goodwin Street, East Hartford, CT., 06108 (860) 528-9838

# Material Safety Data Sheet

Date Prepared 12/17/2010

<b>SECTION I - IDENTIFICATION</b>	HAZARD RATING 0 = Least 1 = Slight 2 = Moderate 3 = Serious 4 = Extreme	Health	2	
		Flammability	2	
IDENTITY (As Used on Label)	Armor Top Hardener		Reactivity	1
COMMON NAME	Aliphatic Polyisocyanate Resin Solution		Personal Protection	G

SECTION II - PRODUCT COMPONENTS	CAS.#	OSHA PEL	ACGIH TLV
Homopolymer of HDI	28182-81-2	N.E. <sup>1</sup>	N.E.
Hexamethylene Diisocyanate (HDI) <sup>2</sup>	822-06-0	N.E.	0.005ppm
Dipropylene glycol monomethyl ether acetate	88917-22-0	N.E.	N.E.
Methyl-1,3-dioxolan-2-one	108-32-7	N.E.	N.E.

<sup>1</sup>not established

<sup>2</sup>Residual monomer content is less than 0.5% based on resin solids at the time of manufacture.

T.S.C.A. Status - O.K. on all above components.

**\*FOR SPILL, LEAK, FIRE, OR ACCIDENT, CALL CHEMTREC 24-HOUR EMERGENCY NUMBER 1-800-424-9300\***

SECTION III - PHYSICAL/CHEMICAL CHARACTERISTICS				
Boiling Point	DPMA	392°F	Specific Gravity (H <sub>2</sub> O = 1)	1.11
Vapor Pressure (mm Hg)	HDI	4.7 x 10 <sup>-7</sup>	Melting Point	N/A
Vapor Density (AIR = 1)	DPMA	6.6	Evaporation rate (Butyl Acetate = 1)	0.015
Volatile Organic Compounds (VOC) = 74 grams/liter				
Solubility in Water NOT SOLUBLE.				
Appearance and Odor Clear, mild ester-like odor.				

## SECTION IV - FIRE and EXPLOSION HAZARD DATA

Flash Point (Closed Cup Method)	186°F	Flammable Limits	LEL	UEL
			1.21 vol%	5.35 vol%
Extinguishing Media	Dry Chemicals, CO <sub>2</sub> , Universal Type Foam.			

Special Firefighting Procedures

Wear full protective equipment including self-contained breathing apparatus. During a fire, HDI vapors and other irritating, highly toxic gases may be generated by thermal decomposition or combustion. Closed container may explode when exposed to extreme heat or burst when contaminated with water (CO<sub>2</sub> evolved).

Unusual Fire and Explosion Hazards

Spills of this on hot fibrous insulations may lead to lowering of the autoignition temperatures resulting in possible spontaneous combustion

## SECTION V - REACTIVITY DATA

Stability	Unstable		Conditions to Avoid
	Stable	X	Keep containers closed when not in use. Avoid static discharge. Flammable vapors released at elevated temps.
Incompatibility (Materials to Avoid) Avoid oxidizers and phosphorus-containing materials.			
Hazardous Decomposition or Byproducts Fire may yield carbon monoxide and/or carbon dioxide.			
Hazardous Polymerization	May Occur	X	Conditions to Avoid
	Will Not Occur		Contact with moisture or other materials which react with isocyanates or temperatures above 400F.

## SECTION VI - HEALTH HAZARD DATA

Route(s) of Entry:	Inhalation?	Skin?	Ingestion?
	Yes	YES	Yes

Signs and Symptoms of Exposure Irritation and redness of skin and eyes. Breathing difficulty.

### Health Hazards (Acute and Chronic)

ACUTE - prolonged skin exposure can cause irritation, dermatitis. Inhalation of vapors can cause nasal and respiratory irritation, dizziness, headache, nausea.

CHRONIC - prolonged or repeated exposure to vapors may cause lung damage as well as increased sensitivity.

Carcinogenicity:	NTP?	IARC Monographs?	OSHA Regulated?
	NO	NO	NO

### Medical Conditions Generally Aggravated by Exposure

Asthma and other respiratory disorders(bronchitis, emphysema, hyperreactivity), skin allergies, eczema.

### Emergency and First Aid Procedures

EYES - Flush with water, holding lids open for 15 minutes or more. Call physician for advice if necessary.

Skin - remove contaminate clothing. Clean affected area with mild soap and water. If irritation or redness develops, seek medical attention.

INHALATION- move person away from source of exposure and into fresh air. If person is not breathing, give artificial respiration and seek medical attention immediately. If breathing difficulty develops, give oxygen and seek medical attention immediately.

**\*\*NOTE\*\* PERSONS WITH LUNG DISORDERS OR WHO ARE SENSITIZED SHOULD NOT USE THIS PRODUCT.**

## SECTION VII - CONTROL MEASURES

Respiratory Protection (Specify Type) Use NIOSH approved respirator as outlined in 30CFR11 and 29CFR 1910.134 effective for solvent and diisocyanate vapors.

Ventilation	Local Exhaust	Use in confined areas.	Special	Explosion proof fans when needed.
	Mechanical	Must be sufficient to maintain area below established TLV/PEL.		

Protective Gloves	Neoprene rubber gloves.	Eye Protection	Splash proof goggles.
-------------------	-------------------------	----------------	-----------------------

### Other Protective Clothing or Equipment

Use other protective equipment such as rubber aprons and a face shield if danger of splashing is possible.

Eye wash station or clear water must be readily available. ENFORCE GOOD HYGIENE PRACTICES. No smoking or open lights in work area. Exposure to liquid, vapors, mists or fumes must be minimized.

Work/Hygienic Practices Launder contaminated clothing before use. Dispose contaminated leather shoes

## SECTION VIII - PRECAUTIONS FOR SAFE HANDLING AND USE

### Steps to be Taken in Case Material is Released or Spilled

Shut off and eliminate all ignition sources. Keep people away. Add sand, earth or other absorbent to spill area. Ventilate confined spaces. Open windows and doors, minimize breathing vapors and skin contact. Keep spill out of sewers by diking. Observe precautions for volatile, flammable vapors from absorbed material.

### Waste Disposal Method

Incineration in accordance with local, state, and federal regulations.

Precautions to be Taken in Handling and Storing Keep containers tightly closed when not in use and away from excessive heat and flame. DO NOT pressurize, cut, weld, solder, drill or grind the containers.

Other Precautions Store in an OSHA approved area for flammable materials.

Prepared by William H. Greider, Jr. Technical Director

**PLEASE NOTE** "The above information is accurate to the best of our knowledge. However, since data, safety standards, and government regulations are subject to change and the conditions of handling and use, or misuse, are beyond our control, Dur-A-Flex, Inc. MAKES NO WARRANTY, EITHER EXPRESS OR IMPLIED, WITH RESPECT TO THE COMPLETENESS OR CONTINUING ACCURACY OF THE INFORMATION CONTAINED HEREIN AND DISCLAIMS ALL LIABILITY FOR RELIANCE THEREON. User should satisfy himself that he has all current data relevant to his particular use."



**DUR-A-FLEX**  
INNOVATION FROM THE FLOOR UP

95 Goodwin Street, East Hartford, CT., 06108 (860) 528-9838

# Material Safety Data Sheet

Date Prepared 8/2/2010

<b>SECTION I - IDENTIFICATION</b>	HAZARD RATING 0 = Least 1 = Slight 2 = Moderate 3 = High 4 = Extreme	Health	1
		Flammability	0
		Reactivity	0
		Personal Protection	A

**IDENTITY (As Used on Label)** Dur-A-Chips/ Cryl-A-Chips

**COMMON NAME** Pigmented Vinyl Flakes

SECTION II - PRODUCT COMPONENTS	CAS.#	OSHA PEL	ACGIH TLV
Ethylene Glycol	107-21-1	NE <sup>1</sup>	50ppm

<sup>1</sup>None Established

T.S.C.A. Status - O.K. on all components

**\*FOR SPILL, LEAK, FIRE, OR ACCIDENT, CALL CHEMTREC 24-HOUR EMERGENCY NUMBER 1-800-424-9300\***

## SECTION III - PHYSICAL/CHEMICAL CHARACTERISTICS

Boiling Point	N/A	Specific Gravity (H2O = 1)	2.5
Vapor Pressure (mm Hg)	N/A	Melting Point	N/A
Vapor Density (AIR = 1)	N/A	Evaporation rate (Butyl Acetate = 1)	N/A
Volatile Organic Compounds (VOC) = Zero grams/liter			
Solubility in Water	Insoluble		
Appearance and Odor	Various colored flakes.		

## SECTION IV - FIRE and EXPLOSION HAZARD DATA

Flash Point (Closed Cup Method)	N/A	Flammable Limits	LEL	UEL
			N/A	N/A
Extinguishing Media	Water or carbon dioxide			
Special Firefighting Procedures	Use respiratory masks to remove smoke and organic vapors.			
Unusual Fire and Explosion Hazards	When polymer burns, water, carbon dioxide, carbon monoxide and smoke are produced.			

## SECTION V - REACTIVITY DATA

Stability	Unstable	X	Conditions to Avoid
	Stable		Sulfuric acid and alkali materials .
Incompatibility (Materials to Avoid)	None known		
Hazardous Decomposition or Byproducts	Upon burning - acetic acid, acetaldehyde, carbon dioxide.		
Hazardous Polymerization	May Occur	X	Conditions to Avoid
	Will Not Occur		None known

## SECTION VI - HEALTH HAZARD DATA

Route(s) of Entry:	Inhalation?	Skin?	Ingestion?
	Yes	No	Possible

Signs and Symptoms of Exposure      Bronchial irritation.

Health Hazards (Acute and Chronic)

No toxic effects have been noted from inhalation or ingestion in animals with exposure. Human health effects of overexposure may include a respiratory irritation with cough and shortness of breath. Individuals with pre-existing lung diseases may react more to over-exposure.

Carcinogenicity:	NTP?	IARC Monographs?	OSHA Regulated?
	No	No	No

Medical Conditions Generally Aggravated by Exposure

May aggravate pre-existing respiratory conditions.

Emergency and First Aid Procedures

Wash dust from the skin with soap and water. Flush out eyes with generous amounts of water for at least 15 minutes. See a physician if necessary.

## SECTION VII - CONTROL MEASURES

Respiratory Protection (Specify Type)

Provide adequate exhaust ventilation; use a NIOSH approved respirator if PELs/TLVs are exceeded.

Ventilation	Local Exhaust	Use when needed.	Special	None
	Mechanical	Not usually required.		

Protective Gloves	Not usually required.	Eye Protection	Safety glasses.
-------------------	-----------------------	----------------	-----------------

Other Protective Clothing or Equipment

Use a dust mask in a dusty environment.

Work/Hygienic Practices      Nothing unusual. Avoid dust.

## SECTION VIII - PRECAUTIONS FOR SAFE HANDLING AND USE

Steps to be Taken in Case Material is Released or Spilled

Not a RCRA listed hazardous waste. Sweep up and/or shovel or use a vacuum to clean up spillage.

Deposit into covered container for disposal.

Waste Disposal Method

Dispose of according to Federal, State, or local regulations. If approved, remove to land disposal area.

Precautions to be Taken in Handling and Storing

In case of skin contact, the compound is not likely to be hazardous but cleaning the skin after use is advisable.

Other Precautions      None known

Prepared by      Samet Dy - Urethane Chemist

**PLEASE NOTE** "The above information is accurate to the best of our knowledge. However, since data, safety standards, and government regulations are subject to change and the conditions of handling and use, or misuse, are beyond our control, Dur-A-Flex, Inc. MAKES NO WARRANTY, EITHER EXPRESS OR IMPLIED, WITH RESPECT TO THE COMPLETENESS OR CONTINUING ACCURACY OF THE INFORMATION CONTAINED HEREIN AND DISCLAIMS ALL LIABILITY FOR RELIANCE THEREON. User should satisfy himself that he has all current data relevant to his particular use."

## **ARMOR TOP**

### **DESCRIPTION**

ARMOR TOP is a two, three or four component aliphatic urethane protective coating. It was formulated for high traffic areas to protect against chemicals and wear. It is available in either a clear or pigmented, gloss or satin finish, and with or without high wear resistant aluminum oxide (grit).

### **BENEFITS**

- VOC- 0 g/L clear (<100 g/L pigmented)
- Low Odor
- Light Stable
- Excellent Abrasion Resistance, 3 to 4 times better than other urethanes; 9 times better than epoxies
- Excellent Chemical Resistance

### **TYPICAL USES**

It is designed to be used as a final topcoat over DUR-A-FLEX epoxy systems.

### **COLORS**

ARMOR-TOP is available clear or in 15 standard colors. Please refer to the Standard Color Chart on our website. Custom colors are available upon request.

### **LIMITATIONS**

Do not drip and leave excess material on the floor as this could lead to blistering. ARMOR TOP should not be applied more than 3 mils wet. During application, DO NOT use 9 inch rollers and make sure that the floor temperature and materials are between 60°F and 80°F. Do not coat floor if moisture is present. Do not coat floor unless floor temp is more than 5 degrees over the dew point. Do not apply if RH >80% Do not apply Natural/Clear ARMOR TOP over DUR-A-GLAZE #4 with FAST or COLD CURE Hardener. Dry Time is slower when Relative Humidity is less than 30%.

**When recoating Armor-Top after the re-coat window has passed (24 hours or longer), aggressively sand the floor using a floor machine with 36 grit paper to remove gloss then solvent wipe with Xylene. Apply DUR-A-GLAZE TIE-COAT as a binder primer for succeeding coat. At 60°F the Tie-Coat primer must cure for a minimum of 16 hours. Please refer to the Tie-Coat PDS on our website for complete application instructions.**

### **APPLICATION INSTRUCTIONS**

**NOTE:** DUR-A-GLAZE #4 Reg. Hardener/Water Clear with DUR-A-GLAZE #4 Resin/SHOP FLOOR or DUR-A-GARD Regular with DUR-A-GARD Resin should be used as the undercoat for this system. ARMOR TOP is typically applied using the dip and roll method with a 18" long 3/8" nap roller with a Wide Boy™ or Big Ben™ frame. Applicators should wear spiked shoes (cross roll). DUR-A-FLEX, Inc. recommends Big Ben™ roller frames when using white or light colors.

1. Pour ARMOR TOP hardener into a 2 gallon bucket. If color is desired, add ARMOR TOP Colorant; mix for 30 seconds. Add ARMOR TOP resin and mix for 30 seconds. If specified, slowly add ARMOR TOP Grit and continue mixing for an additional minute. Pour a small amount into a dip and roll tray that is large enough to accommodate an 18 inch roller.

2. Dip roller cover into paint tray and roll off excess. Apply two 8-10 foot long paths left to right then right to left. Re-wet roller and continue application. Even out roller lines by using W shaped crosses and/or up & down passes. If not even, re-roll up and down until uniform. A final cross-roll is necessary to even out roller lines.

3. Occasionally remix ARMOR TOP in tray or bucket with a stick to prevent settling of the grit/powder.

4. For line striping applications use Dur-a-Gard Bright Yellow with Superstick. Topcoat with Armor Top Bright Yellow.

### **ARMOR TOP KIT SPREAD RATES**

Gloss Clear (w/grit)	= 650 SF/kit
Gloss Clear (no grit)	= 625 SF/kit
Gloss Pigmented (w/grit)	= 775 SF/kit
Gloss Pigmented (no grit)	= 750 SF/kit

Satin Clear (w/grit)	= 775 SF/kit
Satin Clear (no grit)	= 750 SF/kit
Satin Pigmented (w/grit)	= 850 SF/kit
Satin Pigmented (no grit)	= 825 SF/kit

**NOTE: Armor Top is sold in kits only. Spread rates vary due to differences in gloss and satin kit sizes.**

# ARMOR-TOP

## TECHNICAL INFORMATION

VOC in g/L	0 - clear <100 pigmented
% Solids by Weight % Solids by Volume	95.2 92.5
Tensile Strength, psi, ASTM D 2370	7,000
Hardness ASTM D 3363	>4H
Taber Abrasion Resistance A&B ASTM D 4060, 1000g load, 1000 cycles, CS-17 wheel after full cure	<u>Gloss finish</u> <u>Satin finish</u> with grit - 4 mg. loss              with grit - 8 mg. loss no grit - 10 mg. loss                no grit - 12 mg. loss
Adhesion ASTM D 4541	Substrate Failure
UV Resistance	Excellent
Coefficient of Friction ASTM D 2047	>0.60
60° Gloss ASTM D 523	Gloss: 75 +/-10    Satin: 50 +/-10
Mixed Viscosity (Brookfield, 25°C, CPS)	500
Flash Point, Closed cup test	110°F
Pot life, 70° F, 50% R.H.	2 hours
Working time on Floor, 70°F, 50% R.H.	30 minutes
Recoat Window	< 24 hours
Drying properties, 70°F, 50% R.H. 60°F, 30% R.H. 80°F, 70% R.H.	8 hours Tack Free, 12 hours Dry 12 hours Tack Free, 18 hours Dry 4 hours Tack Free, 6 hours Dry
Full Chemical Resistance	7 days

### MOISTURE CONCERNS

Please refer to the Floor Evaluation Flow Chart in the Contractor's Center of our website in the Contractor's center of our website.

### JOINT GUIDELINES

Refer to the Joint Guidelines for complete details on our website.

### PACKAGING

ARMOR TOP is available in kits only.

### CLEANING

This product is considered a low maintenance flooring solution; however certain textures and service environments do require certain procedures. Please refer to the master Cleaning Guide on our website.

### CAUTION

Follow the Hazardous Materials Identification System labeling guide for proper personal protective equipment to use when handling this product. Use only as directed.

**KEEP OUT OF REACH OF CHILDREN.**

## ARMOR-STAT ESD FLOOR SYSTEM

**IMPORTANT!** Read these instructions carefully several days prior to starting your work. Seek answers to any questions you may have before you begin. DUR-A-FLEX, Inc. maintains a Technical Staff that will be glad to answer your questions and give you advice pertaining to your particular installation.

### INSTALLATION OVERVIEW

The general steps required to install this system are:

1. Prepare the slab: shot blast, patch
2. Prime with DUR-A-GLAZE #4 ESD PRIMER
3. Install copper foil grounding tape
4. Install DUR-A-GARD ESD
5. Install ARMOR-STAT ESD TOPCOAT
6. Honor joints
7. Test resistivity at 24 hrs.

### SURFACE PREPARATION

Surface must be sound, dry and perfectly clean, free of all oil, grease, detergent film, sealers and/or curing compounds. A surface profile of CSP 2 to 3 is appropriate for most applications. All epoxy coatings should be removed unless it is properly bonded, totally de-glossed, high quality epoxy. If going over existing coating apply DUR-A-GLAZE TIE-COAT II. Upper level rooms, like mechanical rooms, bathrooms, or wet process areas that have space below should receive ELAST-O-COAT seamless fluid applied membrane. Please refer to the DUR-A-FLEX **Surface Preparation Guide** for detailed instructions.

### JOINT GUIDELINES

Refer to the **Joint Guidelines** on our website for complete details.

### MIXING AREA

Select a convenient mix area and protect the surface from spillage by covering with a layer of cardboard and/or sheet of plastic. Be generous with the amount of space you allocate for this function. The more comfortably your mixer works, the less likely you are to have a "mix error". Make ready all necessary tools, mix and measure containers, etc. **DO NOT MIX ANY EPOXY UNTIL READY FOR IMMEDIATE USE.** Once hardener and resin are combined, it must be used without delay, working time is dependent on size of batch and the temperature of the floor and product. To obtain neat, straight, chip resistant edges at termination points and/or drains, a "keyed edge" must be installed.

with NO-SAG # 1 for moving joints, and DUR-A-GLAZE #4 mixed with NO-SAG #2 or FLINTSHOT for non-moving joints. **BE SURE TO LEAVE AS LITTLE EXCESS AS POSSIBLE AS IT WILL BE HIGHLIGHTED IN SUCCESSIVE STEPS.** Sanding or grinding pre-patch areas will help to hide deviations.

### PRIMING WITH DUR-A-GLAZE #4 ESD PRIMER

All surfaces must be primed with DUR-A-GLAZE #4 ESD PRIMER as soon as the surface has been prepared. Due to the porosity of the concrete, the possibility of out gassing may occur after shot blasting, if this occurs, a second primer coat is needed.

1. Pre-mix hardener and resin components separately before combining.
2. DUR-A-GLAZE #4 ESD PRIMER is mixed 1 part Hardener to 2 parts Resin. Measure out 1/2 gallon of DUR-A-GLAZE #4 ESD PRIMER Hardener and 1 gallon of DUR-A-GLAZE #4 ESD PRIMER Resin. When combining, be sure to add the hardener first. Add the resin and scrape out the container. Be careful to pour both hardener and resin into the center of the mixing pail. Mix the blended epoxy with a slow speed power drill with a Jiffler mixing blade for 2 minutes. Always scrape the sides and bottom of the mixing bucket to assure thorough blending.
3. Pour a 4 to 6 inch "ribbon" of blended epoxy onto the floor (typically along the far wall or a joint). DUR-A-GLAZE #4 ESD PRIMER is typically applied at 200 Sq Ft per gallon to yield 8 mils DFT per coat with a 1/8" notched squeegee. Back roll with a quality non-shed 3/8" nap roller. While wearing spiked shoes, cross roll entire area as you go. Be sure to remove any impurities as you see them. It is much harder to cut or grind them out after the product has cured. Allow to cure.

## **COPPER FOIL TAPE INSTALLATION**

Install Copper foil tape conductive adhesive to ground (such as metal support columns). Copper foil tape is available from McMaster-Carr Company ([www.mcmaster.com](http://www.mcmaster.com)). Dur-A-Flex, Inc. recommends using the ½” tape with conductive adhesive part number 76555A642. Copper foil tape should be installed across joints at each end of the slab and at one point per 1,000 square feet minimum.

## **QUALITY CONTROL**

The color of DUR-A-GARD ESD resin may vary slightly from batch to batch. It is recommended that the lot number on the side of the resin pail be checked, if lot numbers are different, segregate and apply each lot contiguously to minimize slight color variations on the floor.

## **BODY COAT WITH DUR-A-GARD ESD**

After priming with DUR-A-GLAZE #4 ESD PRIMER and installing Copper foil tape to grounds, apply DUR-A-GARD ESD.

1. Pre-mix hardener and resin components separately before combining.

2. DUR-A-GARD ESD is mixed in a 1part Hardener to 3 parts Resin mix ratio. Measure out 1/2 gallon of DUR-A-GARD ESD hardener and 1 1/2 gallons of DUR-A-GARD ESD resin. When combining, be sure to add the hardener first. Add the resin and scrape out the container. Be careful to pour both hardener and resin into the center of the mixing pail. Mix the blended epoxy with a slow speed power drill with a Jiffler mixing blade for 3 minutes. Always scrape the sides and bottom of the mixing bucket to assure thorough blending.

3. Pour a 4 to 6 inch “ribbon” of blended epoxy onto the floor (typically along the far wall or a joint). DUR-A-GARD ESD is applied at 100 Sq Ft per gallon to yield 16 mils WFT per coat with a 3/16” notched squeegee and then back rolled with a quality non-shed 3/8” nap roller. While wearing spiked shoes, cross roll entire area as you go. Be sure to remove any impurities as you see them. Allow to cure.

## **TOPCOAT WITH ARMOR-STAT ESD TOPCOAT**

ARMOR-STAT ESD TOPCOAT is typically applied using the dip and roll method with a 18” long 3/8” nap roller with a Wide Boy™ or Big Ben™ frame. Applicators should wear spiked shoes (cross roll).

DUR-A-FLEX, Inc. recommends Big Ben™ roller frames when using white or light colors.

1. Pour ARMOR-STAT ESD hardener into a 2 gallon bucket. Pre-mix the Armor-Stat resin by shaking the resin can vigorously or mix with a Jiffler for 45 seconds. Add ARMOR-STAT ESD resin and mix for 30 seconds. If specified, slowly add ARMOR-STAT ESD Grit and continue mixing for an additional minute. Pour a small amount into a dip and roll tray that is large enough to accommodate an 18 inch roller.

2. Dip roller cover into paint tray and roll off excess. Apply two 8-10 foot long paths left to right then right to left. Re-wet roller and continue application by using up & down passes. If not even, re-roll up and down until uniform. A final cross-roll is necessary to even out roller lines within 10 minutes. Spread at a rate of 560 sq. ft. per kit with grit, and 535 sq. ft. per kit without grit.

3. Occasionally remix ARMOR-STAT ESD TOPCOAT in tray or bucket with a stick to prevent settling of the grit/powder.

## **TESTING RESISTIVITY**

Once ARMOR-STAT ESD TOPCOAT has cured for 24 hours at 70°F, resistance readings should be taken to ensure the floor is reading properly. DUR-A-FLEX, Inc. recommends using the OHM-STAT RT-1000 Megohmmeter from Static Solutions. Floor readings should be tested at 100V and read between 10<sup>6</sup>-10<sup>9</sup> Ω/Square.

## **IMPORTANT!**

**Increasing room temperature to accelerate cure is not recommended, a slight reduction (3°-5°F) from reasonable room temperature may help reduce out gassing. Special care should be given to avoid surface contamination. USE SIGNS AND BARRIERS to keep traffic out of the area. Do not allow any water on coated surface for 24-48 hours, depending on temperature. Chemical spillage must be prevented for approximately 5 days. NOTE: Use DUR-A-SOLVE for clean up. This product is suitable for applications between 60° and 85° F concrete slab temperature.**

**DO NOT THIN DUR-A-GLAZE #4 ESD PRIMER OR DUR-A-GARD ESD WITH SOLVENT.**

## **CAUTION**

Follow the Hazardous Materials Identification System labeling guide for proper personal protective equipment to use when handling this product. Use only as directed. KEEP OUT OF REACH OF CHILDREN.

*Before using any DUR-A-FLEX, Inc. Product, be sure the Material Safety Data Sheet is read and understood.*



95 Goodwin Street, East Hartford, CT., 06108 (860) 528-9838

# Material Safety Data Sheet

Date Prepared 12/17/2010

## SECTION I - IDENTIFICATION

**IDENTITY (As Used on Label)** **Armor Top Resin**  
**COMMON NAME** Blocked Cycloaliphatic Diamine

HAZARD RATING 0 = Least 1 = Slight 2 = Moderate 3 = High 4 = Extreme	Health	3
	Flammability	1
	Reactivity	0
	Personal Protection	G

## SECTION II - PRODUCT COMPONENTS

	CAS.#	OSHA PEL	ACGIH TLV
Blocked Cycloaliphatic Diamine	Proprietary <sup>2</sup>	N.E. <sup>1</sup>	N.E.

<sup>1</sup>None Established

<sup>2</sup>The manufacturer of the component states that they will provide additional information to a health professional in the event of a medical emergency.

T.S.C.A. Status - O.K. on all above components.

**\*FOR SPILL, LEAK, FIRE, OR ACCIDENT, CALL CHEMTREC 24-HOUR EMERGENCY NUMBER 1-800-424-9300\***

## SECTION III - PHYSICAL/CHEMICAL CHARACTERISTICS

Boiling Point	N.E.	Specific Gravity (H2O = 1)	0.8-0.9
Vapor Pressure (mm Hg)	N.E.	Melting Point	N/A
Vapor Density (AIR = 1)	N/A	Evaporation rate (Butyl Acetate = 1)	N/A

Volatiles Organic Compounds = Zero grams/liter

Solubility in Water Minimal, Reacts slowly with water

Appearance and Odor Pale yellow colored liquid. Amine odor.

## SECTION IV - FIRE and EXPLOSION HAZARD DATA

Flash Point (Closed Cup Method)	171°F	Flammable Limits	LEL	UEL
			N/A	N/A

Extinguishing Media Dry chemicals, carbon dioxide, foam, water spray.

Special Firefighting Procedures

Firefighters should wear full emergency equipment with self-contained breathing apparatus. Irritating gases may be generated by fire.

Cool exposed containers with cold water spray to prevent pressure buildup that may rupture the containers.

## SECTION V - REACTIVITY DATA

Stability	Unstable		Conditions to Avoid
	Stable	X	Keep container closed when not in use, protect from moisture.
Incompatibility (Materials to Avoid)		Strong oxidizers, alkaline materials and acids. Avoid moisture prior to use	
Hazardous Decomposition or Byproducts		By Fire- carbon monoxide, carbon dioxide, aldehydes, nitrogen.	
Hazardous Polymerization	May Occur		Conditions to Avoid Decomposition products from hydrolysis in water isophorone diamine and isobutylaldehyde
	Will Not Occur	X	

## SECTION VI - HEALTH HAZARD DATA

Route(s) of Entry:	Inhalation?	Skin?	Ingestion?
	YES	YES	YES

Signs and Symptoms of Exposure      Irritation on skin.

Health Hazards (Acute and Chronic)      Note: Persons with lung disorders or who are sensitized should not use this product.

ACUTE - Irritation on skin and dermatitis. Corrosive

CHRONIC - Repeated overexposure will cause severe skin irritation, dermatitis and sensitization.

Sensitized persons may experience rapid irritation of skin upon exposure.

Carcinogenicity:	NTP?	IARC Monographs?	OSHA Regulated?
	NO	NO	NO

Medical Conditions Generally Aggravated by Exposure  
Allergy, skin disorders.

Emergency and First Aid Procedures

EYES - **CORROSIVE**: Flush with water, holding lids open for 15 minutes or more. Call physician for advice if necessary.

SKIN - **CORROSIVE**; PROMPTLY wash with soap and water. DO NOT wash with solvents. Seek medical advice if irritation develops or persists.

INHALATION - Move person to fresh air if effects occur. If needed, give oxygen or artificial respiration to improve breathing. Consult physician.

INGESTION - Get medical attention immediately. Never give liquids to an unconscious or convulsing person.

## SECTION VII - CONTROL MEASURES

Respiratory Protection (Specify Type)

Provide adequate exhaust ventilation; use a NIOSH - approved respirator if PELS/TLVS are exceeded.

Ventilation	Local Exhaust	If needed.	Special	None known.
	Mechanical	Adequate exhaust ventilation must exhaust AWAY from applicator.		

Protective Gloves	Natural or Neoprene gloves.	Eye Protection	Splash goggles or face shield.
-------------------	-----------------------------	----------------	--------------------------------

Other Protective Clothing or Equipment

Use rubber apron, face shield and appropriate clothing to prevent contact with skin. Launder contaminated clothing before reuse. Protective skin creams help cleaning with soap and water, gloves must still be worn. An eye wash station or an adequate supply of clean water must be available at work area.

Work/Hygienic Practices      Enforce careful handling to prevent splashing. Wash thoroughly after use.

## SECTION VIII - PRECAUTIONS FOR SAFE HANDLING AND USE

Steps to be Taken in Case Material is Released or Spilled

Wear protective equipment to prevent exposure. Stop spill and dike to prevent spreading. Cover spill with absorbent materials and collect into containers. Clean contaminated area with detergent and water or a steam cleaner for best results.

Waste Disposal Method

Dispose in accordance with Federal, State, and Local requirements.

Precautions to be Taken in Handling and Storing

Keep containers tightly closed when not in use.

Other Precautions      NONE KNOWN.

Prepared by      William H. Greider, Jr. Technical Director

**PLEASE NOTE** "The above information is accurate to the best of our knowledge. However, since data, safety standards, and government regulations are subject to change and the conditions of handling and use, or misuse, are beyond our control, Dur-A-Flex, Inc. MAKES NO WARRANTY, EITHER EXPRESS OR IMPLIED, WITH RESPECT TO THE COMPLETENESS OR CONTINUING ACCURACY OF THE INFORMATION CONTAINED HEREIN AND DISCLAIMS ALL LIABILITY FOR RELIANCE THEREON. User should satisfy himself that he has all current data relevant to his particular use."



95 Goodwin Street, East Hartford, CT., 06108 (860) 528-9838

# Material Safety Data Sheet

Date Prepared 12/17/2010

<b>SECTION I - IDENTIFICATION</b>	HAZARD RATING 0 = Least 1 = Slight 2 = Moderate 3 = Serious 4 = Extreme	Health	2	
		Flammability	2	
IDENTITY (As Used on Label)	Armor Top Hardener		Reactivity	1
COMMON NAME	Aliphatic Polyisocyanate Resin Solution		Personal Protection	G

SECTION II - PRODUCT COMPONENTS	CAS.#	OSHA PEL	ACGIH TLV
Homopolymer of HDI	28182-81-2	N.E. <sup>1</sup>	N.E.
Hexamethylene Diisocyanate (HDI) <sup>2</sup>	822-06-0	N.E.	0.005ppm
Dipropylene glycol monomethyl ether acetate	88917-22-0	N.E.	N.E.
Methyl-1,3-dioxolan-2-one	108-32-7	N.E.	N.E.

<sup>1</sup>not established

<sup>2</sup>Residual monomer content is less than 0.5% based on resin solids at the time of manufacture.

T.S.C.A. Status - O.K. on all above components.

**\*FOR SPILL, LEAK, FIRE, OR ACCIDENT, CALL CHEMTREC 24-HOUR EMERGENCY NUMBER 1-800-424-9300\***

SECTION III - PHYSICAL/CHEMICAL CHARACTERISTICS				
Boiling Point	DPMA	392°F	Specific Gravity (H <sub>2</sub> O = 1)	1.11
Vapor Pressure (mm Hg)	HDI	4.7 x 10 <sup>-7</sup>	Melting Point	N/A
Vapor Density (AIR = 1)	DPMA	6.6	Evaporation rate (Butyl Acetate = 1)	0.015
Volatile Organic Compounds (VOC) = 74 grams/liter				
Solubility in Water NOT SOLUBLE.				
Appearance and Odor Clear, mild ester-like odor.				

## SECTION IV - FIRE and EXPLOSION HAZARD DATA

Flash Point (Closed Cup Method)	186°F	Flammable Limits	LEL	UEL
			1.21 vol%	5.35 vol%
Extinguishing Media	Dry Chemicals, CO <sub>2</sub> , Universal Type Foam.			

### Special Firefighting Procedures

Wear full protective equipment including self-contained breathing apparatus. During a fire, HDI vapors and other irritating, highly toxic gases may be generated by thermal decomposition or combustion. Closed container may explode when exposed to extreme heat or burst when contaminated with water (CO<sub>2</sub> evolved).

### Unusual Fire and Explosion Hazards

Spills of this on hot fibrous insulations may lead to lowering of the autoignition temperatures resulting in possible spontaneous combustion

## SECTION V - REACTIVITY DATA

Stability	Unstable		Conditions to Avoid
	Stable	X	Keep containers closed when not in use. Avoid static discharge. Flammable vapors released at elevated temps.
Incompatibility (Materials to Avoid) Avoid oxidizers and phosphorus-containing materials.			
Hazardous Decomposition or Byproducts Fire may yield carbon monoxide and/or carbon dioxide.			
Hazardous Polymerization	May Occur	X	Conditions to Avoid
	Will Not Occur		Contact with moisture or other materials which react with isocyanates or temperatures above 400F.

## SECTION VI - HEALTH HAZARD DATA

Route(s) of Entry:	Inhalation? Yes	Skin? YES	Ingestion? Yes
--------------------	--------------------	--------------	-------------------

Signs and Symptoms of Exposure Irritation and redness of skin and eyes. Breathing difficulty.

### Health Hazards (Acute and Chronic)

ACUTE - prolonged skin exposure can cause irritation, dermatitis. Inhalation of vapors can cause nasal and respiratory irritation, dizziness, headache, nausea.

CHRONIC - prolonged or repeated exposure to vapors may cause lung damage as well as increased sensitivity.

Carcinogenicity:	NTP? NO	IARC Monographs? NO	OSHA Regulated? NO
------------------	------------	------------------------	-----------------------

### Medical Conditions Generally Aggravated by Exposure

Asthma and other respiratory disorders(bronchitis, emphysema, hyperreactivity), skin allergies, eczema.

### Emergency and First Aid Procedures

EYES - Flush with water, holding lids open for 15 minutes or more. Call physician for advice if necessary.

Skin - remove contaminate clothing. Clean affected area with mild soap and water. If irritation or redness develops, seek medical attention.

INHALATION- move person away from source of exposure and into fresh air. If person is not breathing, give artificial respiration and seek medical attention immediately. If breathing difficulty develops, give oxygen and seek medical attention immediately.

**\*\*NOTE\*\* PERSONS WITH LUNG DISORDERS OR WHO ARE SENSITIZED SHOULD NOT USE THIS PRODUCT.**

## SECTION VII - CONTROL MEASURES

Respiratory Protection (Specify Type) Use NIOSH approved respirator as outlined in 30CFR11 and 29CFR 1910.134 effective for solvent and diisocyanate vapors.

Ventilation	Local Exhaust	Use in confined areas.	Special	Explosion proof fans when needed.
	Mechanical	Must be sufficient to maintain area below established TLV/PEL.		

Protective Gloves	Neoprene rubber gloves.	Eye Protection	Splash proof goggles.
-------------------	-------------------------	----------------	-----------------------

### Other Protective Clothing or Equipment

Use other protective equipment such as rubber aprons and a face shield if danger of splashing is possible.

Eye wash station or clear water must be readily available. ENFORCE GOOD HYGIENE PRACTICES. No smoking or open lights in work area. Exposure to liquid, vapors, mists or fumes must be minimized.

Work/Hygienic Practices Launder contaminated clothing before use. Dispose contaminated leather shoes

## SECTION VIII - PRECAUTIONS FOR SAFE HANDLING AND USE

### Steps to be Taken in Case Material is Released or Spilled

Shut off and eliminate all ignition sources. Keep people away. Add sand, earth or other absorbent to spill area. Ventilate confined spaces. Open windows and doors, minimize breathing vapors and skin contact. Keep spill out of sewers by diking. Observe precautions for volatile, flammable vapors from absorbed material.

### Waste Disposal Method

Incineration in accordance with local, state, and federal regulations.

Precautions to be Taken in Handling and Storing Keep containers tightly closed when not in use and away from excessive heat and flame. DO NOT pressurize, cut, weld, solder, drill or grind the containers.

Other Precautions Store in an OSHA approved area for flammable materials.

Prepared by William H. Greider, Jr. Technical Director

**PLEASE NOTE** "The above information is accurate to the best of our knowledge. However, since data, safety standards, and government regulations are subject to change and the conditions of handling and use, or misuse, are beyond our control, Dur-A-Flex, Inc. MAKES NO WARRANTY, EITHER EXPRESS OR IMPLIED, WITH RESPECT TO THE COMPLETENESS OR CONTINUING ACCURACY OF THE INFORMATION CONTAINED HEREIN AND DISCLAIMS ALL LIABILITY FOR RELIANCE THEREON. User should satisfy himself that he has all current data relevant to his particular use."



**DUR-A-FLEX**  
INNOVATION FROM THE FLOOR UP

95 Goodwin Street, East Hartford, CT., 06108 (860) 528-9838

# Material Safety Data Sheet

Date Prepared 12/17/2010

<b>SECTION I - IDENTIFICATION</b>	<b>HAZARD RATING</b> 0 = Least 1 = Slight 2 = Moderate 3 = High 4 = Extreme	Health	1
		Flammability	2
		Reactivity	0
		Personal Protection	G
<b>IDENTITY (As Used on Label)</b>	Armor Top Colorant: all colors		
<b>COMMON NAME</b>	Liquid Colorant Additive for Urethane		

## SECTION II - PRODUCT COMPONENTS

	CAS.#	OSHA PEL	ACGIH TLV
Dipropylene glycol monomethyl ether acetate	88917-22-0	NE <sup>1</sup>	NE
Titanium Dioxide	13463-67-7	15mg/m <sup>3</sup> (Dust)	10mmg/m <sup>3</sup>
Red Iron Oxide	1332-37-2	10mg/m <sup>3</sup>	5mg/m <sup>3</sup>
Yellow Iron Oxide	51274-00-1	NE	NE
Carbon Black	1333-86-4	3.5mg/m <sup>3</sup> (dust)	3.5mg/m <sup>3</sup> (dust)
<sup>1</sup> not established			

T.S.C.A. Status - O.K. on all above components.

**\*FOR SPILL, LEAK, FIRE, OR ACCIDENT, CALL CHEMTREC 24-HOUR EMERGENCY NUMBER 1-800-424-9300\***

## SECTION III - PHYSICAL/CHEMICAL CHARACTERISTICS

Boiling Point	DPMA	392°F	Specific Gravity (H2O = 1)	1.11
Vapor Pressure (mm Hg)	77 °F	0.05	Melting Point	N/A
Vapor Density (AIR = 1)	DPMA	6.6	Evaporation rate (Butyl Acetate = 1)	0.015
Volatile Organic Compounds (VOC) = 74 grams/liter				
Solubility in Water	NOT SOLUBLE.			
Appearance and Odor	Clear, mild ester-like odor.			

## SECTION IV - FIRE and EXPLOSION HAZARD DATA

Flash Point (Closed Cup Method)	186°F	Flammable Limits	LEL	UEL
		N/A	1.21 vol%	5.35 vol%
Extinguishing Media	Dry Chemicals, CO <sub>2</sub> , Universal Type Foam.			
Special Firefighting Procedures	Wear full protective equipment including self-contained breathing apparatus. During a fire, HDI vapors and other irritating, highly toxic gases may be generated by thermal decomposition or combustion. Closed container may explode when exposed to extreme heat or burst when contaminated with water (CO <sub>2</sub> evolved).			
Unusual Fire and Explosion Hazards	Spills of this on hot fibrous insulations may lead to lowering of the autoignition temperatures resulting in possible spontaneous combustion			

## SECTION V - REACTIVITY DATA

Stability	Unstable		Conditions to Avoid Keep containers closed when not in use. Avoid static discharge. Flammable vapors released at elevated temps.
	Stable	X	
Incompatibility (Materials to Avoid)	Avoid oxidizers and phosphorus-containing materials.		
Hazardous Decomposition or Byproducts	Fire may yield carbon monoxide and/or carbon dioxide.		
Hazardous Polymerization	May Occur	X	Conditions to Avoid Contact with moisture or other materials which react with isocyanates or temperatures above 400F.
	Will Not Occur		

## SECTION VI - HEALTH HAZARD DATA

Route(s) of Entry:	Inhalation?	Skin?	Ingestion?
	Yes	YES	Yes

Signs and Symptoms of Exposure      Irritation and redness of skin and eyes. Breathing difficulty.

### Health Hazards (Acute and Chronic)

ACUTE - prolonged skin exposure can cause irritation, dermatitis. Inhalation of vapors can cause nasal and respiratory irritation, dizziness, headache, nausea.

CHRONIC - prolonged or repeated exposure to vapors may cause lung damage as well as increased sensitivity.

Carcinogenicity:	NTP?	IARC Monographs?	OSHA Regulated?
	NO	NO	NO

### Medical Conditions Generally Aggravated by Exposure

Asthma and other respiratory disorders (bronchitis, emphysema, hyperreactivity), skin allergies, eczema.

### Emergency and First Aid Procedures

EYES - Flush with water, holding lids open for 15 minutes or more. Call physician for advice if necessary.

Skin - remove contaminated clothing. Clean affected area with mild soap and water. If irritation or redness develops, seek medical attention.

INHALATION - move person away from source of exposure and into fresh air. If person is not breathing, give artificial respiration and seek medical attention immediately. If breathing difficulty develops, give oxygen and seek medical attention immediately.

**\*\*NOTE\*\* PERSONS WITH LUNG DISORDERS OR WHO ARE SENSITIZED SHOULD NOT USE THIS PRODUCT.**

## SECTION VII - CONTROL MEASURES

Respiratory Protection (Specify Type)      Use NIOSH approved respirator as outlined in 30CFR11 and 29CFR 1910.134

effective for solvent and diisocyanate vapors.

Ventilation	Local Exhaust	Use in confined areas.	Special	Explosion proof fans when needed.
	Mechanical	Must be sufficient to maintain area below established TLV/PEL.		

Protective Gloves	Neoprene rubber gloves.	Eye Protection	Splash proof goggles.
-------------------	-------------------------	----------------	-----------------------

### Other Protective Clothing or Equipment

Use other protective equipment such as rubber aprons and a face shield if danger of splashing is possible.

Eye wash station or clear water must be readily available. ENFORCE GOOD HYGIENE PRACTICES. No smoking or open lights in work area. Exposure to liquid, vapors, mists or fumes must be minimized.

Work/Hygienic Practices      Launder contaminated clothing before use. Dispose contaminated leather shoes

## SECTION VIII - PRECAUTIONS FOR SAFE HANDLING AND USE

### Steps to be Taken in Case Material is Released or Spilled

Shut off and eliminate all ignition sources. Keep people away. Add sand, earth or other absorbent to spill area. Ventilate confined spaces. Open windows and doors, minimize breathing vapors and skin contact. Keep spill out of sewers by diking. Observe precautions for volatile, flammable vapors from absorbed material.

### Waste Disposal Method

Incineration in accordance with local, state, and federal regulations.

Precautions to be Taken in Handling and Storing      Keep containers tightly closed when not in use and away from excessive heat and flame. DO NOT pressurize, cut, weld, solder, drill or grind the containers.

Other Precautions      Store in an OSHA approved area for flammable materials.

Prepared by      William H. Greider, Jr. Technical Director

### PLEASE

### NOTE

"The above information is accurate to the best of our knowledge. However, since data, safety standards, and government regulations are subject to change and the conditions of handling and use, or misuse, are beyond our control, Dur-A-Flex, Inc. MAKES NO WARRANTY, EITHER EXPRESS OR IMPLIED, WITH RESPECT TO THE COMPLETENESS OR CONTINUING ACCURACY OF THE INFORMATION CONTAINED HEREIN AND use."



**SECTION VI - HEALTH HAZARD DATA**

Route(s) of Entry:	Inhalation? Yes	Skin?	Ingestion? Eyes
--------------------	--------------------	-------	--------------------

Signs and Symptoms of Exposure: Temporary Inhalation Discomfort.

Health Hazards (Acute and Chronic)  
  
 ACUTE - None known other than possible temporary discomfort due to inhalation of dust concentration.  
 CHRONIC - Potential chronic respiratory distress/irritation. Can aggravate pre-existing lung conditions.

Carcinogenicity:	NTP? NO	IARC Monographs? NO	OSHA Regulated? NO
------------------	------------	------------------------	-----------------------

Medical Conditions Generally Aggravated by Exposure  
None Known.

Emergency and First Aid Procedures  
  
 EYES - hold eyes apart and flush with clean water for 15 minutes. If irritation or redness develops and persists seek medical attention.  
  
 INHALATION - For inhalation discomfort move person to fresh air.

**SECTION VII - CONTROL MEASURES**

Respiratory Protection (Specify Type)

Provide adequate exhaust ventilation; use a NIOSH - approved respirator if PELS/TLVS are exceeded.

Ventilation	Local Exhaust	If necessary.	Special	None Known
	Mechanical	Adequate for dusty environments		

Protective Gloves: Wear gloves  
 Eye Protection: Safety goggles, do not wear contact lenses.

Other Protective Clothing or Equipment  
NONE KNOWN.

Work/Hygienic Practices: Avoid unnecessary formation of dust.

**SECTION VIII - PRECAUTIONS FOR SAFE HANDLING AND USE**

Steps to be Taken in Case Material is Released or Spilled  
  
 Non - Skid Grit may be swept or vacuumed for normal disposal.

Waste Disposal Method  
Non - Skid Grit is not a hazardous waste under U.S. Federal RCRA regulations.

Precautions to be Taken in Handling and Storing  
Same as given in Section VII (ventilation, gloves, and goggles.)

Other Precautions: Dry powders can build static charges when subjected to friction.

Prepared by: William H. Greider, Jr. Technical Director

**PLEASE NOTE** "The above information is accurate to the best of our knowledge. However, since data, safety standards, and government regulations are subject to change and the conditions of handling and use, or misuse, are beyond our control, Dur-A-Flex, Inc. MAKES NO WARRANTY, EITHER EXPRESS OR IMPLIED, WITH RESPECT TO THE COMPLETENESS OR CONTINUING ACCURACY OF THE INFORMATION CONTAINED HEREIN AND use."



**OLIVE BEIGE**

DUR-A-FLEX



**ROYAL BLUE**

DUR-A-FLEX

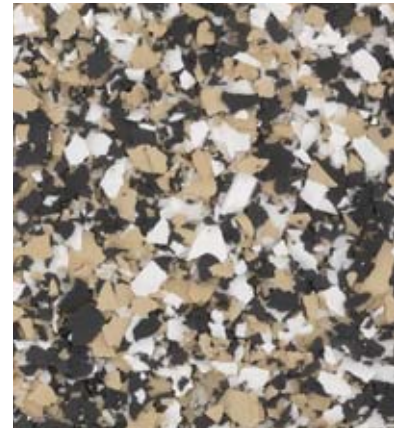

**OYSTERSHELL**



**BOULDER GREY**

DUR-A-FLEX



**DELTA GREEN**

DUR-A-FLEX



**EGGSHELL**



**CRUSHED GRANITE**

DUR-A-FLEX



**BROWNSTONE**

DUR-A-FLEX

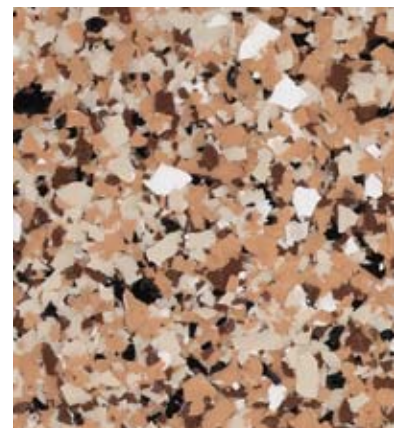

**SANTA FE**

The samples shown are only close approximations and should not be used for specification purposes. Contact Dur-A-Flex to obtain actual samples for best color selection.





**SHALE**

DUR-A-FLEX

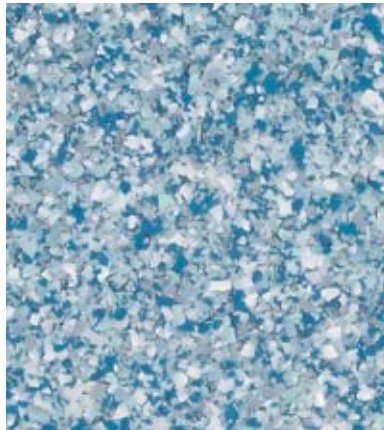

**SKY**

DUR-A-FLEX



**GRAPHITE**



**BLUE MICA\***

DUR-A-FLEX



**DESERT TAN**

DUR-A-FLEX



**CONFETTI**

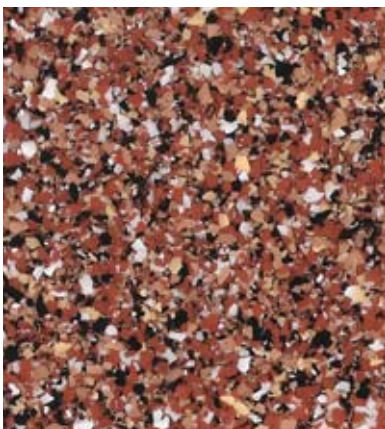

**AUTUMN**

DUR-A-FLEX



**ASH**

DUR-A-FLEX



**SAGE**

The samples shown are only close approximations and should not be used for specification purposes.  
Contact Dur-A-Flex to obtain actual samples for best color selection.  
\*Blue Mica contains silver metallic chip.

DUR-A-FLEX, INC. has developed this document to help Facility Owners, Architects, Engineers, Specification Writers, and Contractors gain a better understanding of the importance of a properly prepared substrate, and the methods to achieve an appropriate bond. This document is intended to be a general guideline, for specific jobsite information, please contact your local DUR-A-FLEX Representative.

There are many satisfactory methods of preparing a substrate to receive a DUR-A-FLEX flooring system. The preparation method is typically chosen based on service requirements, time allowed for entire process and accessibility.

### **PERSONAL PROTECTION EQUIPMENT**

It is the responsibility of the surface preparation contractor and the flooring contractor to insure that all personnel are properly protected from hazards. DUR-A-FLEX is committed to promoting awareness regarding these potential hazards. All DUR-A-FLEX products are rated according to the Hazardous Material Identification System (HMIS). OSHA regulations specify when, where and how workers are to be protected. These regulations and the local OSHA officials should be consulted as necessary to insure proper protection, compliance with the law, and to avoid liability issues. Safety and health issues should be addressed prior to the start the job.

### **TESTING**

#### **MOISTURE CONCERNS**

Please refer to the [Floor Evaluation Flow Chart](#) in the Contractor's Center of our website for a step-by-step process to determine the condition of the concrete.

#### **Testing For An Existing Sealer**

Test to see if the floor is "sealed" by pouring a small amount of muriatic acid on the floor in several spots. If it "froths" instantly, the floor is not sealed. If the acid doesn't froth immediately, a sealer and/or paint is present and must be removed by scarifying, steel shot blasting or other mechanical methods.

#### **Salt Contamination Testing**

Salt contaminated slabs that contain steel reinforcement are very susceptible to corrosion of the reinforcing steel. As the steel corrodes it expands causing cracking, delamination of

concrete and any toppings bonded to it, and eventually, structural failure of the slab. Obvious signs of chloride or salt contamination are spalled concrete with exposed, rusted reinforcing steel. Testing is recommended to determine the depth of contamination and the extent of corrosion activity. A Litmus Test for pH will determine the presence of chloride or acid contamination, if the pH is below 10.

#### **Bond Test**

The purpose of the bond test is to make sure preparation method is adequate for the primer to bond to the substrate. The test is done only when applying MMA systems. For more information on bond test refer to CRYL-A-PRIME data sheet on our website @ [www.dur-a-flex.com](http://www.dur-a-flex.com).

### **REMOVAL AND REPAIR**

#### **ASTM D 4258-83 Standard practice for surface cleaning concrete for coating.**

This practice includes surface cleaning of concrete to remove grease, dirt, and loose material prior to the application of coatings. Procedures include vacuum cleaning, air blast cleaning, water cleaning, detergent water cleaning, and steam cleaning.

#### **Removal of bond inhibiting contaminants**

This includes, but is not limited to removal of oils, grease, wax, sealers, curing compounds, laitance, salts and any other hydrocarbon based materials. This will ensure that a good bond takes place between the resinous flooring and the concrete substrate.

#### **Removal of Adhesives, Mastics and Membranes**

In many retrofit projects, existing tile, VCT or sheet goods are being replaced with polymer flooring systems. Removal of the floor finish will often leave a layer of some type of mastic, adhesive or membrane. In thin applications these materials can often be totally cleaned up by

shotblasting the concrete. In thicker applications, the steel shot will tend to bounce, requiring additional preparation with the use of scarifying equipment or possibly even the use of chemical strippers. Wherever possible, consult the DUR-A-FLEX Tech Service Department or your local DUR-A-FLEX Flooring Contractor and schedule a site visit to investigate the best removal methods.

**Removal of Existing Seamless Floor**

Like mastics and adhesives, the need to remove an existing seamless floor will occasionally arise. There has been much progress made in the development of equipment for removal of resurfacers. Typically, removal requires a heavy grinder with “rotating heads”. These heads can be outfitted with different “teeth” or carbide “blades” for removal of a particular type of overlay.

**REASONS FOR SURFACE PREPARATION**

Surface preparation of a concrete substrate is required to remove surface laitance to create a surface profile and porosity for adhesion of polymer floor systems.

**METHODS OF SURFACE PREPARATION**

Care should be taken to define the degree of abrasion required for the coating system so that the concrete will not be eroded beyond what is necessary. All concrete surfaces should be abraded to remove laitance and contaminants. The following Table describes the required profiles according to the ICRI guidelines for various coating systems.

Coating	Coating Thickness	Concrete Surface Profile (CSP)
Sealers	3 mil	CSP 2-3
High-Build	10-40 mil	CSP 3-4
Self-Leveling	50 mils-1/8”	CSP 4-5
Polymer Overlay	1/8-1/4”	CSP 5-7

**Shotblasting**

Shotblasting is the recommended method of surface preparation of concrete for most polymer floor installations. Shotblast equipment utilizes an alloy wheel spinning at high speeds to throw small steel particles at the substrate in a controlled, dry, 99% dust-free operation. This process removes surface contamination, adds profile and vacuums the concrete clean in one

process. The size and angularity of shot, along with the travel speed of the unit, can be adjusted to determine the degree of the surface profile. Because shotblasting is a dry preparation process, it allows the installation to begin immediately after completion of prep (surface must be dry before blasting). Shotblasting will also identify weak areas in the surface of the concrete. **NOTE:** When selecting shotblast preparation for thin film coating systems (under 20 mils) be aware that a blast pattern or track lines may be visible.

**Diamond Grinding**

Diamond grinding should only be used in areas inaccessible to shotblasting and then only with coarse diamond wheel.

**Scarifying**

Scarifying is primarily used for the removal of deteriorated concrete, coatings and polymer flooring systems.

**Hand Tool**

Hand tool preparation consists of the use of mechanical tools and equipment designed to abrade or chip away the surface of the concrete. Common tools available include chipping hammers, hand held diamond grinders and concrete crack chasing saws. These tools are typically used to make keyways, prepare edges against walls and columns.

**TYPES OF SUBSTRATES**

**Regular Concrete**

Regular concrete surface must be prepared with a steel shot-blast machine, scarifier, diamond grinder. Floors with oil, grime and grease should first be cleaned with Simoniz 969 Cleaner/Degreaser before preparing. Allow floor to dry. Good ventilation, fans and/or auxiliary heat will accelerate drying time. Do not use oil fired portable heaters.

**Replacement of Structurally Deteriorated Concrete**

Replacement of structurally deteriorated concrete must be done in accordance with The International Concrete Repair Institute (ICRI) Bulletin. Patching material must be a DUR-A-FLEX approved patching material. Make sure of minimum cure time before installation of resinous flooring. DUR-A-FLEX flooring Contractors should be contracted whenever possible to complete these repairs appropriately.

### **Fiber Filled Concrete**

Fiber filled concrete must be burned with a propane weed burner, swept and vacuumed perfectly clean and then primed. When primer has completely cured, the floor must be sanded and tack ragged (This step may not be necessary for thick resurfacing systems).

### **Quarry/Ceramic Tile**

Quarry/Ceramic tile have been successfully resurfaced on many projects without removal of tile and setting bed. A site investigation along with cores through the entire slab will help identify the type of setting bed, the existence of any waterproofing membranes, additional toppings, or other unusual existing conditions. Water trapped within the floor will create long-term sanitation and performance problems.

If the tile is well bonded and placed over an unsaturated latex setting bed, the floor may be resurfaced as follows: Surface must be mechanically abraded with a steel shot-blast machine, scarifier or diamond grinder and vacuumed perfectly clean. "Tack rag" area to remove dust and to soften surface. Apply DUR-A-FLEX recommended Poly-Crete or Hybri-Flex systems or DUR-A-GLAZE TIECOAT or CRYL-A-PRIME P-101 with CRYL-A-BOND MT primer to the entire area immediately and allowed to cure.

### **Existing Epoxy Coating/Resurfacer**

Existing seamless floors may be resealed or resurfaced from time to time due to excessive wear or the need to change the appearance or skid-resistance of the floor. The existing floor should first be cleaned and degreased with EZ-CLEAN floor cleaner/degreaser. It must then be mechanically abraded with a floor-sanding machine or a steel shot blast machine to totally remove gloss. Vacuum perfectly clean. "Tack rag" area to remove dust and to soften surface. Apply DUR-A-GLAZE TIE-COAT to entire area immediately followed by subsequent epoxy coatings.

### **Plywood**

The plywood substrate must be sound and non-flexing under the expected load. Typical plywood substrate must be exterior or marine grade, new, clean, and smooth finish (NO KNOTS.). Two layers with staggered joints are required. Plywood should be positively fastened to the existing surface with a high quality construction adhesive as well as a 6" screw pattern.

For further information on plywood substrates, please contact your local sales representative or DUR-A-FLEX technical department.

### **Walls**

#### **For Dur-A-Wall Applications:**

Block wall: Apply Dulux (ICI) block filler to fill pores over new or existing concrete block following manufacturer's instructions.

Drywall: Drywall must be finished to a level #4 or #5 finish prior to coating. Prime with ICI GRIPPER Multipurpose primer or GLIDDEN GRIPPER primer. Substrate will affect final appearance of wall coating.

Cast in place Concrete and Ceramic Tile:  
Use DUR-A-GLAZE 4 RESIN COVE-REZ thickened with Cab-O-Sil, M5, or No-Sag #2 (1.5 times the resin volume) with DUR-A-GLAZE 4 FAST Hardener to fill pores and cracks.

**Multiple applications of filler material maybe necessary. Sand or grind between coats to achieve a smooth surface.**

**NOTE: Tile and block grout lines may "mirror through" the finished system even though the surface is smooth.**

### **CRACKS AND JOINTS**

Refer to Joint Guidelines for complete details on our website in the Contractor Center section @ [www.dur-a-flex.com](http://www.dur-a-flex.com).

1/2010SURFACEPREP

***Before using any DUR-A-FLEX, Inc. Product, be sure the Material Safety Data Sheet is read and understood.***

Flooring problems on concrete from vapor emission, dew point, alkalinity; pH, etc. cause millions of dollars in repair and replacement costs annually. By recognizing potential problems, testing for and mitigating them, steps can be taken to ensure a long lasting, successful flooring installation.

### **What is the traditional failure mode because of “moisture” problems?**

There are two ways a polymeric floor can fail: (1) the floor system was never able to bond properly at the time of installation or (2) there were factors present at the time of installation to cause the bond to fail. Symptoms of failure on an already installed floor may include bubbles, blisters and/or delamination.

### **What causes a polymeric floor to fail?**

Traditional theory has focused primarily on moisture failure such as capillary and hydrostatic, however more recent research has found that although moisture plays a role, it is not the only factor. In reality, the presence of ionic compounds in the concrete plays an even more significant role. For this reason we strongly recommend that you **do not rely on moisture testing alone to avoid floor failure!**

Through the chemical analysis of several thousand concrete cores we have developed a patent-pending process that can actually predict future moisture blister generation on concrete.

During the evaluation of these cores, we learned some slabs with moisture vapor emission rates of 25 lbs./1000 s.f./24 hours by calcium chloride as well as 95+% RH did not blister. Conversely, we saw slabs with much lower emission rates blister severely. We also understand that many slab owners are paying to install “moisture mitigation systems” to insure the flooring installed on top won’t blister; yet in some cases, **blisters still occur!**

We also learned that specific ionic components of the surface chemistry of the slab (top 0-3/16”(5mm)), when present at certain levels, would predict moisture blisters **100% of the time.** Without this combination of compounds, regardless of the moisture levels, blisters wouldn’t occur.

### **What is the main factor that will cause a failure?**

Osmosis is one of the main factors that can cause floor failure. Osmosis occurs when actual moisture vapor emission through the concrete slab is seeking to equalize the soluble ions at the surface of the concrete slab. This creates a pressure that can be greater than the adhesion strength of the coating. Four conditions are needed for osmosis to occur: (1) a semi-permeable membrane, which

can be the polymer primer or the upper layers of the slab, (2) a gradient of ionic activity (soluble salts), (3) a source of moisture vapor and (4) An impermeable prime, base and/or topcoat. If any one of these is removed, osmotic blistering cannot occur. And we aren’t talking all theory here. We can make blisters happen on command!

### **What is Moisture Vapor Emission?**

Water is added to turn cement, sand and aggregate into a concrete slab. There is a critical volume of water needed to “hydrate” the concrete, and an excess volume of water used to make the concrete pour-able and workable. Moisture Vapor Emission is movement of moisture that is not part of the concrete mix. It could be from ground water, plumbing, or landscaping runoff, etc. This moisture is a concern when the concrete slab has no vapor retarder installed, or the vapor retarder has been punctured.

### **How were moisture failures predicted?**

Up until recently, there were three methods recommended to pre-test for moisture related floor failures; the plastic sheet method, Calcium Chloride using ASTM F1869, and Relative Humidity using ASTM F2170.

### **How will moisture failures be predicted by Dur-a-Flex?**

Dur-A-Flex has developed a flow chart to assist you in determining what floor system will work best based on the test results of core samples and, where appropriate, relative humidity testing. (See flow chart on following page) If you are planning to use our Epoxy or MMA, use in-situ Relative Humidity Testing per ASTM F-2170-02 as a quantitative test method.

Unlike traditional calcium chloride testing, RH as well as core test results are not significantly impacted by ambient temperature and relative humidity conditions in the building.

### **What determines my flooring options?**

Depending on the level of ionic compounds in your core samples, your floor will fall into one of four levels. Your test report will specify this level allowing you to select the best floor option as shown on the flow chart.

# Floor Evaluation Flow Chart

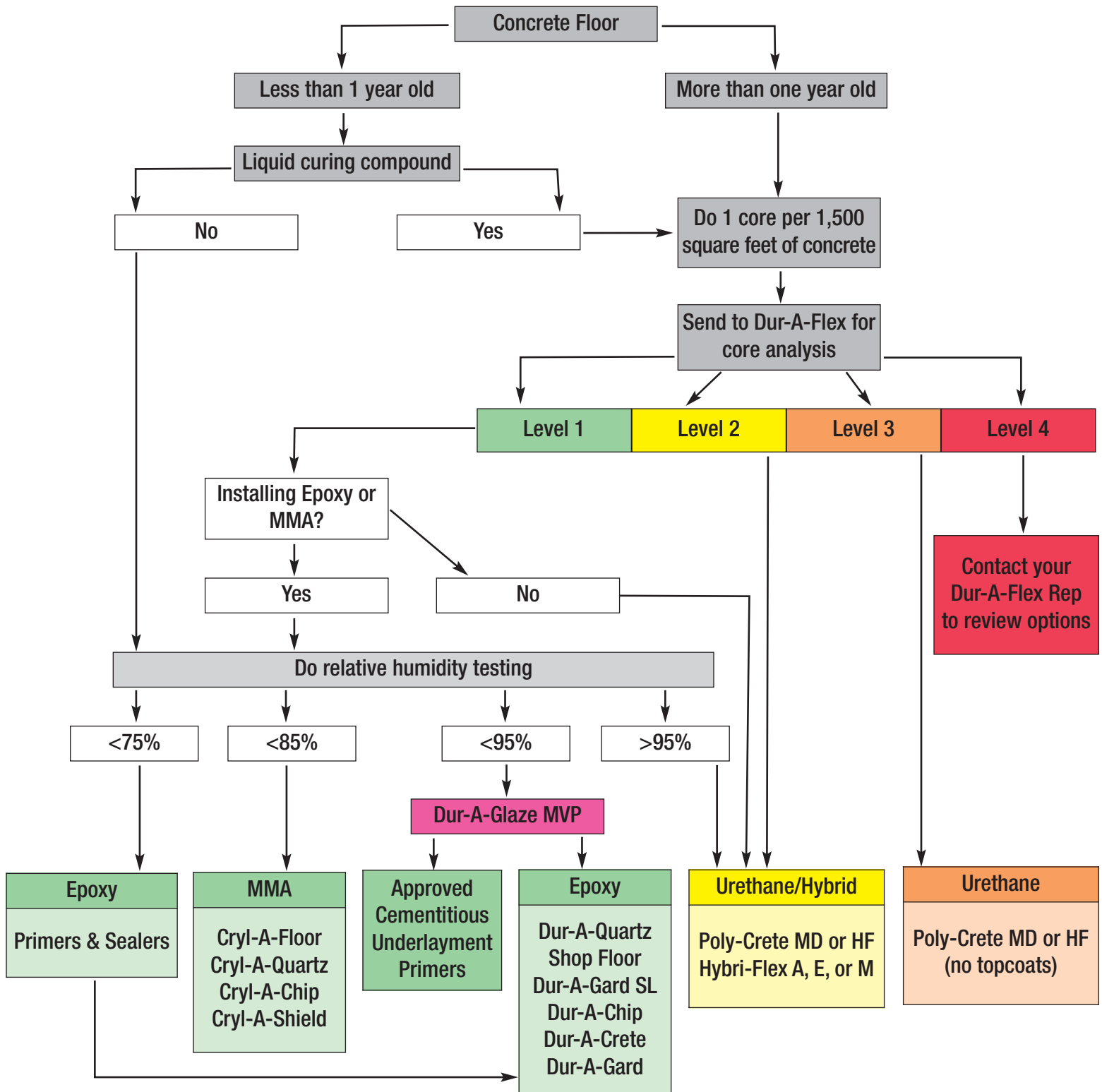

## Dur-A-Flex Chemical Resistance Data

R = Recommended (no change)

S = Splash &amp; spill (slight change)

N = Not recommended (attack)

 \***Bold**\* = Stains

Chemical Name	% Conc.	Epoxies					Urethanes							Acrylics
		Dur-A-Gard	Glaze #4	Nov - olac	Ultra Clear	Armor Top	Glaze #5	Poly-Thane 1	Poly-Thane 2 HS	Poly-Crete HF MD TF	Poly-Crete CF	Poly-Crete KT	MMA	
Acetic Acid	10%	R	R	R	R	R		R	R	R	R	R	R	R
Acetic Acid	30%	S	S	S	R	R		S	R	S	R		R	S
Acetic Acid	50%	N	N	N	R	N		S	R	S	S		S	N
Acetic Acid,3%, and Propionic Acid		R	R	R	R				R	R	R		R	R
Acetone		N	N	N	N		R	S	R	R		R		N
Acid Clean		S	S	S	R				S	S				
ACP-99 Ketone		N	N	N	S				R	R				N
Alum	48%	N	N	N	R				S	S	S		S	R
<b>*Aminoethanolamine*</b>		<b>*R*</b>	<b>*R*</b>	<b>*R*</b>	<b>*R*</b>				<b>*R*</b>	<b>*R*</b>	R		R	<b>*R*</b>
Ammonia	30%	R	R	R	R	R	R		R	R	R	R	R	R
Ammonium Hydroxide	30%	R	R	R	R	R	R	R	R	R	R	R	R	S
Antifreeze		R	R	R	R	R	R	R	R	R	R	R	R	R
Aromatic 100		S	S	S	R				R	R	S		S	
Aromatic hydrocarbons-Super Hiflash 100		S	S	S	R				R	R	S		S	
Benzene		N	N	N	S				R	R	N		N	N
Benzyl Alcohol	Photo	S	S	S	R				R	R	S	S	S	N
<b>Betadine</b>			<b>*S*</b>			<b>*S*</b>	<b>*R*</b>	<b>*S*</b>	<b>*R*</b>	<b>*R*</b>				<b>*R*</b>
Boric Acid	4%	R	R	R	R				R	R	R		R	R
Brake Fluid, DOT 3		S	S	S	S	S	R		R	R	S		S	R
Butanol/Methyl Cellosolve		N	N	N	S				R	R	N		N	N
Butyl Alcohol		S	S	S	R				R	R	S		S	N
Butyl Carbitol		S	S	S	R				R	R				N
Butyl Cellosolve		N	N	N	S				R	R				N
Butyl Cellosolve acetate		N	N	N	S				R	R				N
Carbon Tetrachloride		R	R	R	R				R	R				N
Caustic Soda solution		R	R	R	R				R	R	R	R	R	R
<b>*Chromic Acid*</b>	10%	<b>*R*</b>	<b>*R*</b>	<b>*R*</b>	<b>*R*</b>	<b>*S*</b>	<b>*R*</b>	<b>*S*</b>	<b>*R*</b>	<b>*R*</b>	<b>*R*</b>	<b>*R*</b>	<b>*R*</b>	<b>*R*</b>
<b>*Chromic Acid*</b>	40%	<b>*N*</b>	<b>*N*</b>	<b>*N*</b>	<b>*R*</b>			<b>*S*</b>	<b>*S*</b>	<b>*S*</b>	<b>*S*</b>		<b>*S*</b>	<b>*S*</b>
<b>CIP 200 Cleaner</b>		<b>*N*</b>							R					
Citric Acid	10%	R	R	R	R		R	R	R	R	R	R	R	R
Citric Acid	20%	R	R	R	R				R	R	R	R	R	R
Citric Acid	50%	N	N	N	R			S	R	R	R		R	R
Clorox		R	R	R	R		R	S	R	R	R	R	R	R
Coffee						<b>*S*</b>	<b>*R*</b>							
<b>*Cola*</b>	90C	<b>*N*</b>	<b>*N*</b>	<b>*N*</b>	<b>*N*</b>			<b>*R*</b>	<b>*R*</b>	<b>*R*</b>				<b>*R*</b>
Cola	RT	S	S	S	R	S	R	R	R	R	R		R	R
<b>*Copper Sulfate*</b>		<b>*R*</b>	<b>*R*</b>	<b>*R*</b>	<b>*R*</b>				<b>*R*</b>	<b>*R*</b>	<b>*R*</b>		<b>*R*</b>	<b>*R*</b>
<b>*Cupric Chloride*</b>		<b>*R*</b>	<b>*R*</b>	<b>*R*</b>	<b>*R*</b>				<b>*R*</b>	<b>*R*</b>	<b>*R*</b>		<b>*R*</b>	<b>*R*</b>
Cyclohexanone		S	S	S	R				R	R	S		S	R
Detergent, heavy duty		R	R	R	R	R	R		R	R	R	R	R	R
Diacetone alcohol		N	N	N	S				R	R				N
<b>*Dimethyl ethanol amine*</b>		<b>*R*</b>	<b>*R*</b>	<b>*R*</b>	<b>*R*</b>				<b>*R*</b>	<b>*R*</b>				
<b>*Dimethylamineborane*</b>		<b>*R*</b>	<b>*R*</b>	<b>*R*</b>	<b>*R*</b>				<b>*R*</b>	<b>*R*</b>				
DMF		N	N	N	N				R	R	N		N	
Docosanic Acid (in ethanol)	2.50%	N	N	N	R				R	R	N		N	
Drano- (sodium hydroxide and aluminum)		S	S	S	R	S	R		R	R	R	R	R	
<b>DuraPrep</b>			<b>*S*</b>			<b>*S*</b>	<b>*S*</b>	<b>*S*</b>	<b>*R*</b>	<b>*S*</b>				<b>*S*</b>
<b>Eco-lab AC-3 Cleaner</b>		<b>*N*</b>				<b>N</b>	<b>*S*</b>			<b>*S*</b>		<b>N</b>		
Eco-Lab Wash & Walk		R			R		R				R	R	R	
EEP solvent		N	N	N	S	N	R		R	R	N	S	N	N
Ethanol	95%	N	N	N	S		R	S	R	R	S		S	S
Ethyl Acetate	99%	N	N	N	S				R	R	S	S	S	S
Excellerate Cleaner						R	R					R		
Fluoboric Acid		S	S	S	R				R	R				
<b>*Formaldehyde*</b>	37%	<b>*S*</b>	<b>*S*</b>	<b>*S*</b>	<b>*R*</b>		<b>*R*</b>	<b>*R*</b>	<b>*R*</b>	<b>*R*</b>	<b>*R*</b>	<b>*R*</b>	<b>*R*</b>	<b>*R*</b>
Gasoline		R	R	R	R		R		R	R		R		R
Glycol Ether		N	N	N	S				R	R		R		R
Heating Oil-Home		R	R	R	R			R	R	R	R		R	R
Hexane		N	N	N	S				R	R	R		R	R
Hydraulic fluids		R	R	R	R			R	R	R	R	R	R	R
<b>*Hydrochloric Acid*</b>	20%	<b>*R*</b>	<b>*R*</b>	<b>*R*</b>	<b>*R*</b>			<b>*R*</b>	<b>*R*</b>	<b>*R*</b>	<b>*R*</b>	<b>*R*</b>	<b>*R*</b>	<b>*R*</b>
<b>*Hydrochloric Acid*</b>	37%	<b>*R*</b>	<b>*R*</b>	<b>*R*</b>	<b>*R*</b>		<b>*R*</b>	<b>*S*</b>	<b>*R*</b>	<b>*R*</b>	<b>*R*</b>		<b>*R*</b>	<b>*R*</b>
<b>*Hydrofluoric Acid*</b>	40%	<b>*N*</b>	<b>*N*</b>	<b>*N*</b>	<b>*S*</b>				<b>*R*</b>	<b>*S*</b>		<b>*R*</b>		<b>*R*</b>
Hydrofluosilic Acid	30%	R	R	R	R				R	R				R
Hydrogen Peroxide	30%	S	S	S	R		R	S	R	R	R	R	R	R
Hydrogen Peroxide	50%	N	N	N	R	S	S	N	R	R	R	R	R	R
<b>*Iodine Tincture*</b>	2%	<b>*R*</b>	<b>*R*</b>	<b>*R*</b>	<b>*R*</b>		<b>*R*</b>		<b>*R*</b>	<b>*R*</b>	<b>*R*</b>		<b>*R*</b>	<b>*R*</b>
Isopropanol		S	S	S	R		R	R	R	R	S		S	S
Isopropyl Acetate	99%	S	S	S	R				R	R	S		S	N
Jet Fuel		R	R	R	R		R	R	R	R	R		R	R
Lactic Acid	88%	N	N	N	R	N	N	S	S	N	R	S	R	R
Magnesium Hydroxide		R	R	R	R				R	R	R		R	R
MEK		N	N	N	N			S	S	S	N	S	N	N
Methacrylate Monomer		S	S	S	S			N	S	S	N	N	N	N

# Dur-A-Flex Chemical Resistance Data

R = Recommended (no change)

S = Splash & spill (slight change)

N = Not recommended (attack)

\*Bold\* = Stains

Chemical Name	% Conc.	Epoxies					Urethanes							Acrylics
		Dur-A-Gard	Glaze #4	KF	Nov - olac	Ultra Clear	Armor Top	Glaze #5	Poly-Thane 1	Poly-Thane 2 HS	Poly-Crete HF MD TF	Poly-Crete CF	Poly-Crete KT	MMA
Methanol		N	N	N	N			R	R	N	S	N	N	
Methyl Cellosolve		N	N	N	N			R	R		S		N	
Methyl dipropasol solvent		N	N	N	R			R	R		S		N	
Methylene chloride		N	N	N	N			S	N	N	S	N	N	
MIBK		N	N	N	S		R	R	R	N		N	N	
Mineral Oil		R	R	R	R		R	R	R	R		R	R	
Mineral Spirits		S	S	S	R		R	R	R		R		R	
Mixed Chlorinated Waste Solvents		N	N	N	S			R	R				N	
*Monoethanolamine*		*R*	*R*	*R*	*R*			*R*	*R*					
Motor Oil		R	R	R	R		R	R	R	R		R	R	
Mustard, yellow							*R*							
*Nickel chloride*		*R*	*R*	*R*	*R*			*R*	*R*				*R*	
*Nickel Sulfate*		*R*	*R*	*R*	*R*			*R*	*R*				*R*	
*Nitric Acid*	10%	*S*	*S*	*S*	*R*		*R*	*S*	*R*	*S*			*R*	
*Nitric Acid*	20%	*S*	*S*	*S*	*R*		*S*	*N*	*R*	*R*	*R*	*R*	*R*	
*Nitric Acid*	30%	*N*	*N*	*N*	*R*			*N*	*R*	*R*	*R*	*R*	*S*	
*Nitric Acid*	40%	*N*	*N*	*N*	*R*			*N*	*S*	*S*	*R*	*S*	*N*	
Oleic Acid		R	R	R	R			R	R				R	
Oxalic Acid	10%	R	R	R	R			R	R				R	
Peppermint Oil	100%	R	R	R	R			R	R	R				
Phenolic Paint stripper waste	1-5%	S	S	S	R			R	R				N	
Phosphoric Acid	85%	*R*	*R*	*R*	*R*		*S*	*R*	*R*	*R*	*R*	*R*	*S*	
Phosphorous Trichloride	100%	N	N	N	S			R	R				N	
PM Solvent		N	N	N	S		R	S	R	R		S	N	
Polyester Resin		S	S	S	R			R	R				S	
Polyester resin in styrene		S	S	S	R			R	R				N	
Polyphosphates		R	R	R	R			R	R	R		R	R	
*Potassium Cyanide*		*R*	*R*	*R*	*R*			*R*	*R*				*R*	
Potassium Hydroxide	45%	R	R	R	R	R		*S*	R	R	R	R	R	
*Potassium Permanganate*	solid	*R*	*R*	*R*	*R*			*S*	*R*	*R*	*R*	*R*	*R*	
Propionic Acid	100%	S	S	S	R			R	R					
Propyl Cellosolve		N	N	N	S			N	R	R	N	N		
Propylene Glycol		R	R	R	R		R	R	R	R	R	R	R	
Propylene glycol ether		N	N	N	R		R		R	R	S	S	R	
Red Wine Vinegar						*S*	R					S		
*Silver Cyanide*		*R*	*R*	*R*	*R*				*R*	*R*				
*Silver Nitrate*	20%	*R*	*R*	*R*	*R*				*R*	*R*	*R*		*R*	
Skydrol		S	S	S	R	S	R	S	R	R		R	R	
Sodium Chlorite		R	R	R	R				R	R	R		R	
Sodium Hydroxide	50%	R	R	R	R		R	R	R	R	R	R	R	
Sodium Hypochlorite	15%	R	R	R	R				R	R	R	R	R	
Sodium Hypochlorite	50%	N	N	N	R		R		R	R		R	R	
*Sodium Persulfate*		*R*	*R*	*R*	*R*				*R*	*R*	*R*		*R*	
*Spearment Oil*		*S*	S	S	R				R	R				
Spor-Klenz					*N*			*N*					*N*	
Stoddard solvent		N	N	N	S				R	R	N		N	
Styrene		N	N	N	S				R	R	N		N	
*Sulfuric Acid*	10%	*R*	*R*	*R*	*R*	*R*	*S*	*R*	*R*	*S*	*R*	*R*	*R*	
*Sulfuric Acid*	50%	*N*	*N*	*N*	*R*	N		*S*	*S*	*S*	*R*	*R*	*S*	
*Sulfuric Acid*	75-98%	*N*	*N*	*N*	*R*			*N*	*N*	*N*	*N*	*N*	*N*	
*Tannic Acid*	20%	*R*	*R*	*R*	*R*				*R*	*R*	*R*		*R*	
Tartaric Acid	10%	R	R	R	R				R	R			R	
Terpene Fraction of Spearmint Oil	100%	R	R	R	R				R	R				
Tetrahydrofuran														
Toluol		N	N	N	N				R	R		S		
Transmission Oil		R	R	R	R	S	R		R	R	R	R	R	
Trichloroethane (1,1,1)		S	S	S	R				R	R				
Trichloroethylene		N	N	N	N				R	R	N	S	N	
*Triethanolamine (TEA)*		*S*	*S*	*S*	*R*				R	*S*	R			
*Triethanolpentamine (TEPA)*		*S*	*S*	*S*	*R*				R	*S*				
*Triethanolitetramine (TETA)*		*S*	*S*	*S*	*R*				R	*S*				
Urine		R	R	R	R			R	R	R		R	R	
Vinegar		R	R	R	R			R	R	R	R	R	R	
Water		R	R	R	R			R	R	R	R	R	R	
Wine, cabernet sauvignon						*S*	*R*							
Xylene		S	S	S	R		R	S	R	R	S	S	N	

All data is based on room temperature exposure. Please check with the Dur-A-Flex Technical Department for elevated constant temperature or thermal shock exposure  
 Methodology - Epoxies and Acrylics (MMA) were tested by immersion for Shore D Hardness and weight change at 0, 2, and 7 days  
 - Urethanes were spot tested and checked after 1, 2, and 7 days

83010

**WHY CLEAN YOUR FLOOR?**

**Appearance:** Your floor will look its best when it is clean. By instituting a scheduled cleaning program, the floor will continue to look and perform as it did when it was first installed.

**Safety:** No matter how aggressive the texture of your floor, if it is not cleaned properly, it can present a slip hazard. Emulsifying, rinsing and drying your floor properly will reduce the risk of a slip and fall incident.

**Service Life:** The lifetime of your floor will depend upon how well you clean it. In aggressive use areas (i.e. kitchens and machine shops) contaminants such as oil, dirt and grease work with water and bacteria to attack your floor.

**FLOOR CLEANING PROCESS & TOOLS**

The best way to clean a Dur-A-Flex floor is to use the recommended cleaning product and follow a six-step process. (Equipment needs vary between small and medium/large floor areas.)

Process	Small Area	Medium/Large Area
<b>Sweep</b> floor thoroughly	Broom, dust mop	Floor sweeper, broom
<b>Apply</b> cleaning product on floor surface	Deck brush, Foamer/sprayer	Automatic floor scrubber, Foamer/sprayer
<b>Dwell</b> – allow cleaning product time to emulsify foreign material	10 –15 minutes	10 –15 minutes
<b>Agitate</b> to aid in the release of foreign materials	Deck brush, Rotary floor machine	Automatic floor scrubber, Rotary floor machine
<b>Remove</b> cleaning product from the floor	Squeegee (soft neoprene) Wet vacuum	Automatic floor scrubber
<b>Rinse</b> the floor with clean water and remove	Wet vacuum, Squeegee (soft neoprene)	Automatic floor scrubber

**NOTES:**

- Never use a mop to clean a floor that is greasy or oily.
- Make sure the pads or brushes on the automatic scrubber are in good shape. Pads should be red or blue 3M cleaning pads or similar. Brushes should be nylon non-abrasive Malish 8129 series or a similar medium flex bristle brush.
- When using a deck brush, choose a medium/stiff bristle.
- When using a rotary floor machine, use a tan or red 3M pad or similar.
- When removing solution with a squeegee, use a soft, neoprene squeegee. **Do Not** use a water spray to remove cleaning solution from the floor because it will over-dilute the solution and cause grease and oil to fall back onto the floor.
- **Wax strippers should never be used on a Dur-A-Flex floor.**
- Spills should be cleaned up immediately to prevent staining and as a safety precaution.
- Surfaces should be adequately protected when moving heavy equipment across the floor.
- Through proper training and education, unnecessary wear of the floor (such as forklift spin and skid-marks) can be avoided.

\*Warranties: Seller warrants that its goods, as described on the face hereof, are free from any defects in material or workmanship. Seller makes no other warranty, express or implied, and all implied warranties of merchantability and fitness for a particular purpose are hereby disclaimed. Seller shall not be liable for prospective profits or special indirect or consequential damages. Seller's sole liability and buyer's exclusive remedy for breach of any warranty as expressly limited, at seller's option, to replacement at the original F.O.B. point or refund of purchase price. Seller shall not be responsible for any claim resulting from failure to utilize product in the manner in which it was intended and in accordance with instruction provided for use of product. Any claim for breach of warranty shall be deemed waived unless buyer shall give seller written notice of such claim within sixty (60) days after delivery and shall allow seller reasonable opportunity to investigate claim and inspect product.\*

## **RECOMMENDED CLEANING PRODUCTS**

Determining the correct cleaning product for your DUR-A-FLEX floor is based upon the amount and type of soiling the floor receives. We have divided these into four types, and recommended a cleaning product for each instance:

<b>Application</b>	<b>Typical Areas</b>	<b>Product</b>	<b>Product Description</b>
Traffic Areas (Light soils)	Retail Hallways, Healthcare, Labs, Dining Areas, Schools	EZ-CLEAN	EZ-CLEAN is a heavy-duty alkaline floor cleaner designed to remove protein or crude based soils.
Moderate/Heavy (Protein soils)	Grocery stores, Restaurant kitchens, Animal care, Food/Beverage Processing	EZ-CLEAN	
Moderate/Heavy (Crude soils)	Manufacturing/Industrial, Machine/Automotive Service Centers, Warehouses	SIMONIZ 969	SIMONIZ 969 is a heavy duty, highly alkaline floor cleaner designed to remove machine and crude oil from concrete
Rubber Tire Marks	Forklift tire spin	TIRE MARK REMOVER	TIRE MARK REMOVER is a heavy duty cleaner designed to remove rubber skid marks from polymer type floors as well as hard steel trowels floors.

The above Dur-A-Flex cleaning products may be ordered directly from Dur-A-Flex Customer Service at 1-800-253-3539 or via email at [orders@dur-a-flex.com](mailto:orders@dur-a-flex.com)

## **WHEN TO CLEAN YOUR FLOOR**

Dur-A-Flex floors are designed for and used in heavy traffic areas that typically accumulate foreign matter. Because of this, the recommended maintenance schedule for most areas is **once or twice daily** cleaning and regular “touch-ups” for spills. Less frequent cleaning of these areas results in a buildup of foreign matter, which diminishes the appearance, safety and service life of the floor.

Our CRYL-A-FLEX MMA products develop to full cure in one hour, and full cure for most epoxy and urethane systems is 7 days at 68°F. The lower the room temperature - the longer the cure time. Avoid chemical spills and full traffic during cure period. Premature exposure may cause permanent staining or discoloration. Do Not use abrasive cleaning methods during the first week after installation.

## **WALL CLEANING PROCESS:**

1. Application – Apply EZ-CLEAN at a 1:64 dilution rate with hot water while using a deck brush, foamer/sprayer or power washer.
2. Scrub walls with deck brush.
3. Rinse walls with clean water.

For further technical assistance regarding this guide, please call DUR-A-FLEX, Inc. Technical Services at (800) 253-3539, or e-mail [info@dur-a-flex.com](mailto:info@dur-a-flex.com).

The two basic joint types are Moving (dynamic) and Non-Moving (static).

## Moving Joints

**Construction, Expansion and Isolation** joints are considered moving joints which allow horizontal and vertical movement between the slab and adjoining structures, such as walls and columns, helping to minimize cracking where the two meet.

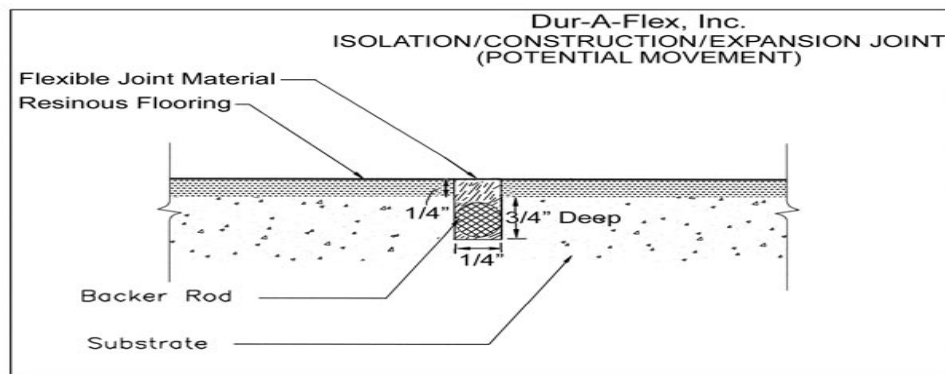

Prior to filling moving joints Dur-A-Flex, Inc. recommends "honoring" these joints by making a saw cut through the finished floor system at a depth of  $\frac{3}{4}$ " deep and  $\frac{1}{4}$ " wide with a diamond blade saw attached to a vacuum. A bond breaker such as backer rod (closed cell) must be added to the bottom of the joint.

**Be sure to mark the location of the joints prior to the installation of the finished floor.**

**Potential cracking and or stress/stretch lines (white lines) may occur on all resinous floor systems over or on either side of moving joints if the joints are not saw cut and properly filled. Also if there is a variance of temperature of 20 degrees or more from the time the joint is filled and coated to its operational temperature, hairline cracking could occur even on non-moving joints.**

## Non-Moving Joints

**Control and or Contraction** joints are considered non-moving joints which accommodate shrinkage and relieve internal stresses during the curing process of the concrete.

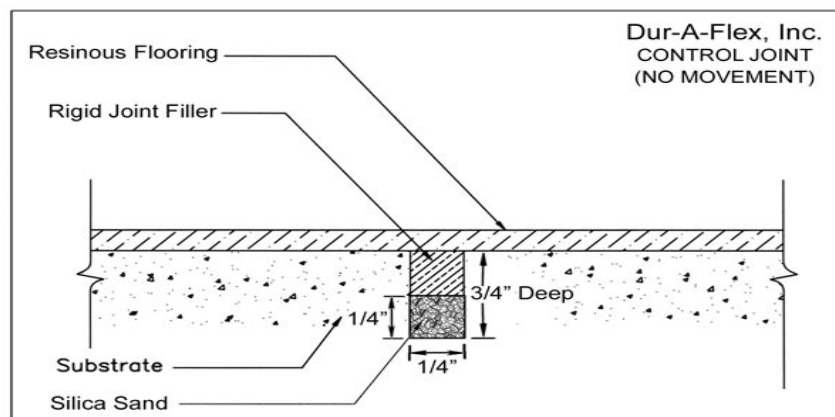

Prior to filling non-moving joints be sure to prepare them by removing all laitance, debris and sealers to a depth of 3/4" deep and 1/4" wide with a diamond blade saw attached to a vacuum. A bond breaker such as silica sand (30-40 mesh) at 1/4" deep may be added to the bottom. This will stop the joint material from seeping if the concrete is cracked through.

**Repair of damaged/spalled joints**

Saw cut each side of spalled area and chip out the center with a chipping hammer or consider the use of a series of blades to reach the proper width. If using multiple blades, the center blade should reach the depth of the original joint and the outer blades should achieve a cut creating a "T" shape after cutting.

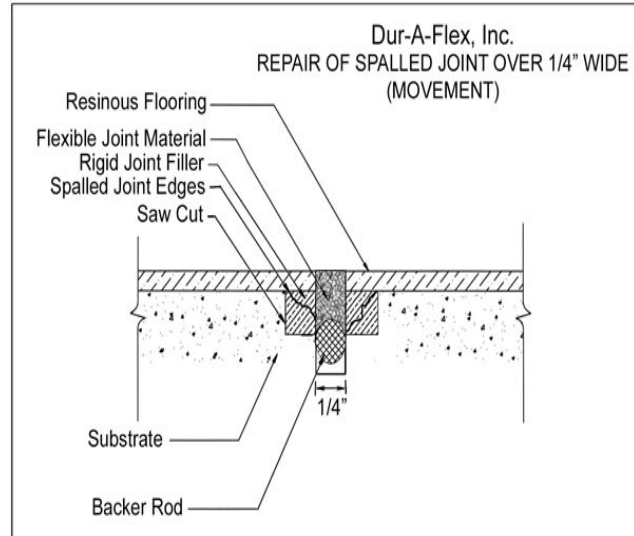
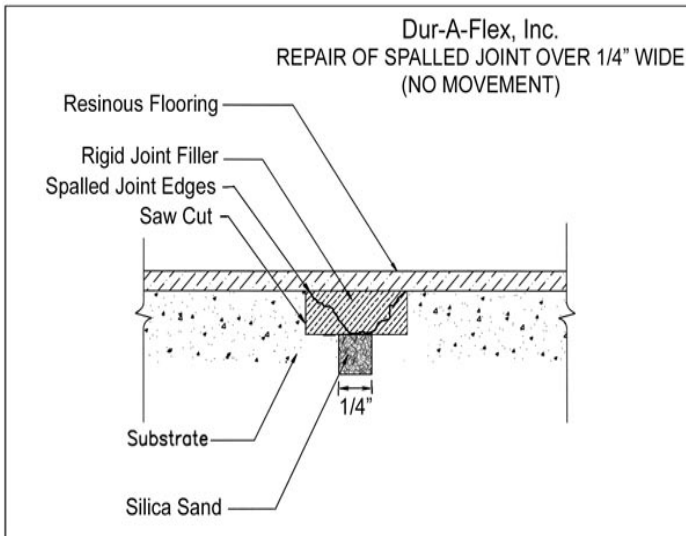

**Installation Timing**

The American Concrete Institute (ACI) recommends that filling of industrial floor joints be deferred 60-90 days after floor slab pour or as long as possible. This is to allow control and construction joints time to open closer to their ultimate width through the concrete shrinkage process. (In freezer/cooler areas, floor should be stabilized at ultimate operating temperature for 7 days prior to installation).

Prior to treatment of joints be sure to contact the facilities owner or manager to determine how long the concrete has cured as well as the location of moving and non-moving joints.

Refer to table below to determine what product is used where:

JOINTS	TYPE	BOND BREAKER	JOINT MATERIAL (1/4 inch wide)	JOINT MATERIAL (over 1/4 inch wide)
Non-moving (Static)	Control/Contraction	Silica Sand (30-40 mesh) at 1/4" deep	<ul style="list-style-type: none"> <li>Epoxy flooring systems use Glaze #4 with Cab-O-Sil (No-Sag #2): Typical mix is 1 pint Glaze #4 hardener, 1 quart Glaze #4 resin, 3 quarts Cab-O-Sil (No-Sag #2)</li> <li>Poly-Crete HF, MD and SL flooring systems typically cover and fill this size crack/joint</li> <li>MMA flooring systems use MMA S/L Filler Mix</li> </ul>	<ul style="list-style-type: none"> <li>Epoxy flooring systems use Glaze #4 with Dur-A-Crete.</li> <li>Poly-Crete flooring systems use Poly-Crete MD or WR</li> <li>MMA flooring systems use SL Filler Mix or Cryl-A-Tex.</li> </ul>
Moving (Dynamic)	Expansion/Construction/ Isolation	Backer Rod 2 X wider than joint	Flexible joint material (Metzger/Mcguire, Versaflex or equivalent)	Flexible joint material (Metzger/Mcguire, Versaflex or equivalent)

**References:**

- ACI 224 "Joints in Concrete Construction"
- ASTM Standards "C 1193-0 and C-920-02"
- National Ready Mixed Concrete Association "Concrete in Practice"
- Metzger/McGuire, Inc.
- SSPC



**DUR-A-FLEX**  
INNOVATION FROM THE FLOOR UP

## Manufacturer's One-Year Limited Warranty

Seller warrants that its goods are free from any defects in material or workmanship and are in conformity with its published specifications, subject to standard tolerances for variations, except that color cannot be warranted as to uniformity of shade or conformity to samples. Seller's sole liability and Customer's exclusive remedy for breach of any warranty as expressly limited, at Seller's option, is to replace material at the original FOB point or refund of the purchase price. A written notice of claim for breach of warranty must be delivered to Seller within sixty (60) days of observation and no more than **one (1) year** after delivery of the product. Seller shall be allowed reasonable opportunity to investigate the claim and inspect the product. In no event may Customer recover damages exceeding the price paid by the Customer for the specific goods as to which the claim is made, whether based on contract, tort, or any other theory.

**SELLER MAKES NO OTHER WARRANTY, EXPRESSED OR IMPLIED, AND ALL IMPLIED WARRANTIES OF FITNESS FOR A PARTICULAR PURPOSE AND OF MERCHANTABILITY ARE HEREBY DISCLAIMED. SELLER SHALL NOT BE LIABLE FOR PROSPECTIVE PROFITS OR SPECIAL, INDIRECT, INCIDENTAL OR CONSEQUENTIAL DAMAGES. ALL WARRANTIES ARE NULL AND VOID IF CUSTOMER HAS NOT PAID IN FULL IN ACCORDANCE WITH SELLER'S PAYMENT TERMS.** Seller shall not be liable for any claim resulting from failure to utilize product in the manner in which it was intended and in accordance with instructions provided for use of product on Dur-A-Flex, Inc.'s web site, product catalogue or otherwise.

Dur-A-Flex, Inc. shall not be liable, and Customer waives all claims made against Dur-A-Flex, Inc. for prospective profits or special, indirect, incidental or consequential damages, or any other damages or remedies not specifically provided above, based upon negligence, breach of warranty, strict liability in tort or any other cause of action. Dur-A-Flex, Inc. will not be liable for, and the Customer shall defend, indemnify and hold harmless (including without limitation costs and attorney's fees) Dur-A-Flex, Inc. from, any loss, damage or injury to persons or property, or claim thereof, resulting from (A) Customer's or any third party's or end user's handling, storage, transportation, resale, application or other use of the goods, or in combination with other substances, or otherwise or (B) selection or recommendation by Dur-A-Flex, Inc. of any applicator or other contractor. Any controversy or claim arising out of or relating to the within Warranty, terms and conditions shall be settled by arbitration in accordance with the commercial arbitration rules of the American Arbitration Association, and judgment upon the award rendered by the arbitrator may be entered in any court having jurisdiction thereof. Venue for the arbitration shall be in Hartford, Connecticut.

Customer & Application:

Agreed and Accepted by:

\_\_\_\_\_  
Patrick J. Meade  
Vice President, Sales & Technical Support

January 1, 2012  
Date

