



**DUR-A-FLEX**  
INNOVATION FROM THE FLOOR UP

## **DUR-A-CRETE SYSTEM** **CRETE GARD TOPCOAT**

### **SUBMITTAL PACKAGE CONTENTS:**

- DUR-A-GLAZE MVP PRIMER-PRODUCT DATA SHEET (OPTIONAL DEPENDING UPON MOISTURE TEST RESULTS)
- DUR-A-GLAZE MVP – MSDS
- DUR-A-GLAZE #4 WB PRIMER – PRODUCT DATA SHEET
- DUR-A-GLAZE #4 WB PRIMER – MSDS
- DUR-A-CRETE – PRODUCT DATA SHEET
- DUR-A-CRETE – APPLICATION INSTRUCTIONS
- DUR-A-GARD – PRODUCT DATA SHEET
- DUR-A-CRETE AGGREGATE-MSDS
- DUR-A-CRETE SYSTEM – MSDS
- STANDARD COLOR CHART
- SURFACE PREPARATION GUIDELINES
- FLOOR EVALUATION GUIDELINES
- FLOOR EVALUATION FLOW CHART
- CHEMICAL RESISTANCE CHART
- CLEANING GUIDELINES
- JOINT GUIDELINES
- STANDARD WARRANTY



## DUR-A-GLAZE MVP Primer

### DESCRIPTION

Dur-A-Flex DUR-A-GLAZE MVP PRIMER is a clear, 100% solids epoxy moisture mitigation system formulated to bond to concrete with relative humidity (RH) as high as 95%. It is designed to reduce moisture vapor emission levels up to 20 lbs/1000 sq. ft./24 hours to 3 lbs/1000 sq. ft./24 hours or less.

### BENEFITS

- Reduces moisture levels to 3 lbs./1,000 sq. ft./24hours or less
- VOC 0 g/L
- Typical one coat application
- Excellent adhesion
- Resistant to high Ph

### TYPICAL USES

- Moisture mitigation system under any epoxy-based Dur-A-Flex flooring system
- Primer over Dur-A-Tex 32
- Use with Dur-A-Flex-approved resilient flooring underlayment primers

### LIMITATIONS

- For interior applications only
- Apply only to properly prepared, sound and stable concrete at least 5 days old.
- DUR-A-GLAZE MVP PRIMER is to be applied at substrate temperatures between 60° F and 90° F.
- Do not apply when RH of concrete is greater than 95% (at 40% depth of slab) or moisture vapor transmission levels are greater than 20 lbs/1000 sq. ft./24 hours
- Recoat window of within 24 hours must be adhered to.
- Do not use as a stand-alone system
- Available clear only
- Does not prevent floor failures due to osmotic blistering. See note on this page under WARRANTY.
- Where Dur-A-Glaze MVP is used with vinyl tile, sheet vinyl, carpet, or any other resilient floor covering, the 10 year warranty is only valid if Dur-A-Glaze MVP is used with Dur-A-Flex-approved cementitious underlayment primers.

### APPLICATION METHOD/ SPREAD RATES

Pour 2 parts resin into 1 part hardener and mix for 2 minutes using a jiffler-type mixer at 300 – 450 rpm.

DUR-A-GLAZE MVP PRIMER is applied with a 3/16 inch V-notched squeegee and back-rolled with a 3/8 inch nap roller cover. Apply at a rate of 100 sq.ft./gallon to yield a dry film thickness of 16 mils.

NOTE: Out-gassing may occur in very porous concrete. To address this, apply a second coat of DUR-A-GLAZE MVP PRIMER mixed with an equal amount of Cab-O-Sil. Apply using a flat squeegee at 250 – 350 square feet per mixed gallon.

### SURFACE PREPARATION

This product requires preparation in order to perform as expected. Surface must be profiled, clean, dry, oil free and sound. Please refer to the Surface Preparation Guide on our website for more information.

Perform anhydrous calcium chloride tests per ASTM F1869 for to determine moisture vapor emission rates and/or in situ probe method testing per ASTM F2170 to determine relative humidity levels.

NOTE: If replacing VCT, note that salt concentration is typically higher where tiles meet. Dur-A-Flex highly recommends core analysis along joint lines prior to installation of any resinous floor system.

### PACKAGING

DUR-A-GLAZE MVP PRIMER is available in 1-gallon cans, 5-gallon pails and 50-gallon drums.

### WARRANTY

A 10 year warranty is available for approved applications with the submission of a warranty application form. The form can be found in the Contractor Center on our website.

NOTE: DUR-A-GLAZE MVP PRIMER is a moisture mitigation system designed to reduce moisture vapor emission only. It will not prevent floor failures caused by osmotic blistering unless ionic components (salts) in the substrate are at acceptable levels. An analysis of the substrate may be obtained using the Dur-A-Flex Floor Evaluation/Moisture Guidelines.

**JOINT GUIDELINES**

**Construction, Expansion and Isolation** joints are considered moving joints which allow horizontal and vertical movement between the slab and adjoining structures, such as walls and columns, helping to minimize cracking where the two meet.

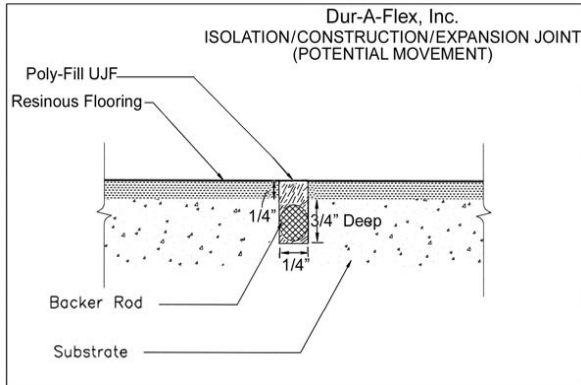

Prior to filling moving joints Dur-A-Flex, Inc. recommends “honoring” these joints by making a saw cut through the finished floor system at a depth of 3/4” deep and 1/4” wide with a diamond blade saw attached to a vacuum. A bond breaker such as backer rod (closed cell) must be added to the bottom of the joint. Use Poly-Fill UJF to fill joint.

**Be sure to mark the location of the joints prior to the installation of the finished floor.**

**Control and or Contraction** joints are considered non-moving joints which accommodate shrinkage and relieve internal stresses during the curing process of the concrete.

Fill joints as follows: Mix 1 part Dur-A-Glaze MVP hardener with 2 parts Dur-A-Glaze MVP resin and thicken with 3 parts Cab-0-Sil.

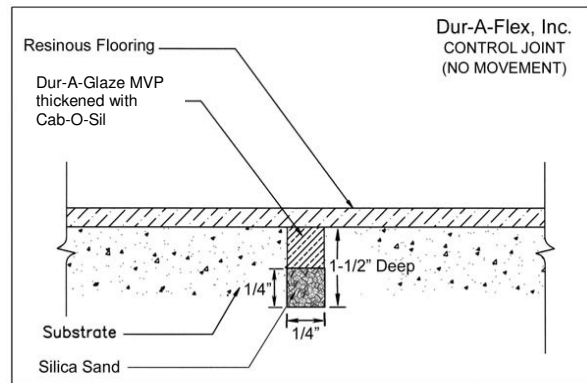

*Before using any Dur-A-Flex, Inc. product, be sure the Material Safety Data Sheet is read and understood.*

**DUR-A-GLAZE MVP PRIMER**

**TECHNICAL INFORMATION**

Resin type	Epoxy	
Color	Clear	
% Solids	100%	
Mix Ratio (by volume)	2 resin to 1 hardener	
Viscosity at 70°F (mixed hardener & resin)	1,400 cps	
Pot Life at 70°F	45 minutes	
Recoat range at 70°F	12 – 24 hours	
Foot traffic	24 hours	
Cured Film Thickness	16 mils at 100 sq. ft. per gallon	
Shelf life	1 year when stored in original packaging at 73° F	
VOC	0 g/L	
Physical Property	Test Method	Result
Hardness, Shore D	ASTM D-2240	75-80
Compressive Strength	ASTM D-695	11,200 psi
Flame Spread /NFPA-101	ASTM E-84	Class A
Tensile Strength	ASTM D-638	2,100 psi
Flexural Strength	ASTM D-790	5,100 psi
Bond Strength to Concrete	ACI-40	Substrate Failure
Water Absorption	MIL D-24613	Nil







## SECTION VI - HEALTH HAZARD DATA

Route(s) of Entry:	Inhalation?	Skin?	Ingestion?
	YES	YES	YES

Signs and Symptoms of Exposure Irritation on skin.

### Health Hazards (Acute and Chronic)

ACUTE - Irritation on skin and dermatitis.

CHRONIC - Repeated overexposure will cause severe skin irritation, dermatitis and sensitization.

Sensitized persons may experience rapid irritation of skin upon exposure.

Carcinogenicity:	NTP?	IARC Monographs?	OSHA Regulated?
	NO	NO	NO

### Medical Conditions Generally Aggravated by Exposure

Allergy, skin disorders.

### Emergency and First Aid Procedures

EYES - Flush with water, holding lids open for 15 minutes or more. Call physician for advice if necessary.

SKIN - PROMPTLY wash with soap and water. DO NOT wash with solvents. Seek medical advice if irritation develops or persists

INHALATION - Move person to fresh air if effects occur. If needed, give oxygen or artificial respiration to improve breathing. Consult physician.

INGESTION - Get medical attention immediately. Never give liquids to an unconscious or convulsing person.

Note: Persons with lung disorders or who are sensitized should not use this product.

## SECTION VII - CONTROL MEASURES

### Respiratory Protection (Specify Type)

Provide adequate exhaust ventilation; use a NIOSH - approved respirator if PELS/TLVS are exceeded.

Ventilation	Local Exhaust	If needed.	Special	None known.
	Mechanical	Adequate exhaust ventilation must exhaust AWAY from applicator.		

Protective Gloves	Natural or Neoprene gloves.	Eye Protection	Splash goggles or face shield.
-------------------	-----------------------------	----------------	--------------------------------

### Other Protective Clothing or Equipment

Use rubber apron, face shield and appropriate clothing to prevent contact with skin. Launder contaminated clothing before reuse. Discard contaminated leather shoes and canvas sneakers. Protective skin creams help cleaning with soap and water, gloves must be still be worn. An eye wash station or an adequate supply of clean water must be available at work area.

Work/Hygienic Practices Enforce careful handling to prevent splashing. Wash thoroughly after use.

## SECTION VIII - PRECAUTIONS FOR SAFE HANDLING AND USE

### Steps to be Taken in Case Material is Released or Spilled

Wear protective equipment to prevent exposure. Stop spill and dike to prevent spreading. Cover spill with absorbent materials and collect into containers. Clean contaminated area with detergent and water or a steam cleaner for best results.

### Waste Disposal Method

Dispose in accordance with Federal, State, and Local requirements.

### Precautions to be Taken in Handling and Storing

Keep containers tightly closed when not in use.

Other Precautions NONE KNOWN.

Prepared by Samet Dy - Chemist

### PLEASE NOTE

"The above information is accurate to the best of our knowledge. However, since data, safety standards, and government regulations are subject to change and the conditions of handling and use, or misuse, are beyond our control, Dur-A-Flex, Inc. MAKES NO WARRANTY, EITHER EXPRESS OR IMPLIED, WITH RESPECT TO THE COMPLETENESS OR CONTINUING ACCURACY OF THE INFORMATION CONTAINED HEREIN AND DISCLAIMS ALL LIABILITY FOR RELIANCE THEREON. User should satisfy himself that he has all current data relevant to his particular use."

## **DUR-A-GLAZE #4 WB PRIMER**

### **DESCRIPTION**

DUR-A-GLAZE #4 WB PRIMER is a water-borne, two component, epoxy designed to prime concrete floors.

### **BENEFITS**

- Low VOC
- Easy to Use
- Long Pot Life
- Low Odor
- Fast Drying
- Excellent Adhesion

### **TYPICAL USES**

DUR-A-GLAZE #4 WB PRIMER is applied clear using **Dur-A-Glaze #4 Resin**.

As a primer for following epoxy systems:

- DUR-A-GARD
- DUR-A-GARD SL
- DUR-A-QUARTZ
- SHOP FLOOR
- DUR-A-CHIP

### **LIMITATIONS**

**This product is designed to be applied at 200 square feet per gallon. Do not apply this product less than 8 mils wet or “out-gassing” can occur.**

Do not use this product to “fill” or “level any surface imperfections. Any build up in excess of 12 mils wet film thickness will not cure properly. Not a UV stable product.

This product is best suited for application in temperatures between 60°F and 90°F. Substrate must be clean, sound, and dry.

Excessive relative humidity of greater than 70% will dramatically prevent migration of water. Proper ventilation to move air is recommended.

Do not use as a stand-alone system.

Protect from freezing. If product freezes, heat-thaw, mix with resin and apply according to instructions.

### **APPLICATION METHOD/SPREAD RATE**

**Mix 4 parts DUR-A-GLAZE #4 WB PRIMER HARDENER to 1 part DUR-A-GLAZE #4 RESIN.**

Recommended spread rate of **200** Sq Ft per gallon mix. Apply with a 1/8” notched squeegee.

Then immediately back roll with a high quality 3/8” nap roller cover. **Be sure to check the spread rate as the material is applied.**

For proper flow and wetting, maintain DUR-A-GLAZE #4 WB PRIMER at room temperature prior to mixing. The hardener and resin should be thoroughly mixed before combining.

Scrape the bottom and sides of each container. The resin and hardener can then be combined and mixed using a **slow**-speed 450 rpm electric drill with a Jiffler type mixing attachment.

2 coats required depending on concrete surface profile.

### **SURFACE PREPARATION**

This product requires preparation in order to perform as expected. Substrate must be roughened, clean, sound, and dry. Please refer to the Surface Preparation guidelines on our website for more information.

### **PACKAGING**

DUR-A-GLAZE #4 WB PRIMER HARDENER is available in 1-gallon cans, 5-gallon pails and 50-gallon drums.

“Warranties: Seller warrants that its goods, as described on the face hereof, are free from any defects in material or workmanship. Seller makes no other warranty, express or implied, and all implied warranties of merchantability and fitness for a particular purpose are hereby disclaimed. Seller shall not be liable for prospective profits or special indirect or consequential damages. Seller’s sole liability and buyer’s exclusive remedy for breach of any warranty as expressly limited, at seller’s option, to replacement at the original F.O.B. point or refund of purchase price. Seller shall not be responsible for any claim resulting from failure to utilize product in the manner in which it was intended and in accordance with instruction provided for use of product. Any claim for breach of warranty shall be deemed waived unless buyer shall give seller written notice of such claim within sixty (60) days after delivery and shall allow seller reasonable opportunity to investigate claim and inspect product.”

# DUR-A-GLAZE #4 WB PRIMER

## TECHNICAL INFORMATION

Finish:	High Gloss
Cure Time at 70°F (foot traffic)	6-8 hours
Pot Life at 90°F:	30 minutes
Pot Life at 70°F	1 hour
Pot Life at 60°F	1 1/2 hours
Re-Coat Window at 70°F	8 -36 Hrs
Spread Rate, Avg. Concrete:	200 sq. ft./gal. DFT = 5 mils @ 200 ft.
Mix Ratio:	4 part hardener to 1 part resin
Color (cured):	Transparent, Clear
Shelf Life:	1 year, unopened containers

Physical Property	Test Method	Result
VOC Content		2 g/L
Solids by volume		56 % +/-5%
Flexibility (1/4: Cylindrical mandrel)	ASTM D-1737	Pass
Elongation	ASTM D-2370	9%
Impact Resistance	ML D-2794	>160
Hardness	ASTM D-3363	3H
Abrasion Resistance	ASTM D-4060	
CS17 wheel (1000g load)	1000 Cycles	30 mg loss
Adhesion	ASTM D-4541	550 psi (Concrete Failure)
Coefficient of Friction	ASTM D-2047	>0.6
60 Gloss	ASTM D-523	85+

### CAUTION

Follow the Hazardous Materials Identification System labeling guide for proper personal protective equipment to use when handling this product. Use only as directed. **KEEP OUT OF REACH OF CHILDREN.**

### MOISTURE CONCERNS

Please refer to the Floor Evaluation Flow Chart in the Contractor's Center of our website for a step-by-step process to determine the condition of the concrete.

*Before using any DUR-A-FLEX, Inc. product, be sure the Material Safety Data Sheet is read and understood.*



**DUR-A-FLEX**  
INNOVATION FROM THE FLOOR UP

95 Goodwin Street, East Hartford, CT., 06108 (860) 528-9838

# Material Safety Data Sheet

Date Prepared 8/2/2010

<b>SECTION I - IDENTIFICATION</b>		HAZARD RATING 0 = Least 1 = Slight 2 = Moderate 3 = High 4 = Extreme	Health	3
IDENTITY (As Used on Label) <b>Dur-A-Glaze #4 WB Primer-Sealer Hardener</b>			Flammability	1
COMMON NAME Emulsified Amine Curative			Reactivity	0
			Personal Protection	G

SECTION II - PRODUCT COMPONENTS	CAS.#	OSHA PEL	ACGIH TLV
Water	7732-18-5	N.E. <sup>1</sup>	N.E.
Polyamine Curative	Proprietary <sup>2</sup>	N.E.	N.E.
Modified Epoxy Resin Adhesion Promotor	Proprietary	N.E.	N.E.

<sup>1</sup>None Established

<sup>2</sup>The manufacturer of the component states that they will provide additional information to a health professional in the event of a medical emergency.

T.S.C.A. Status - O.K. on all above components.

**\*FOR SPILL, LEAK, FIRE, OR ACCIDENT, CALL CHEMTREC 24-HOUR EMERGENCY NUMBER 1-800-424-9300\***

## SECTION III - PHYSICAL/CHEMICAL CHARACTERISTICS

Boiling Point	>400°F	Specific Gravity (H2O = 1)	1.07
Vapor Pressure (mm Hg)	not known	Melting Point	N/A
Vapor Density (AIR = 1)	not known	Evaporation rate (Butyl Acetate = 1)	not known
Volatile Organic Compounds (VOC) = < 2 grams/liter			
Solubility in Water	Soluble		
Appearance and Odor	Pale yellow viscous liquid. Mild ester-like odor.		

## SECTION IV - FIRE and EXPLOSION HAZARD DATA

Flash Point (Closed Cup Method)	212°F	Flammable Limits	LEL	UEL
			N/A	N/A
Extinguishing Media	Water spray, Foam, CO <sub>2</sub> , Dry Chemicals.			
Special Firefighting Procedures	Wear full protective equipment including self-contained breathing apparatus.			
Unusual Fire and Explosion Hazards	Cool storage containers with water spray to prevent pressure build-up that may rupture the containers. Combustion products may be toxic.			

## SECTION V - REACTIVITY DATA

Stability	Unstable		Conditions to Avoid
	Stable	X	None known
Incompatibility (Materials to Avoid)	None known		
Hazardous Decomposition or Byproducts	By Fire - Carbon monoxide, Carbon dioxide, Nitrogen oxides.		
Hazardous Polymerization	May Occur		Conditions to Avoid
	Will Not Occur	X	None known.

**SECTION VI - HEALTH HAZARD DATA**

Route(s) of Entry:	Inhalation?	Skin?	Ingestion?
	YES	YES	YES

Signs and Symptoms of Exposure Irritation of skin.

Health Hazards (Acute and Chronic)

ACUTE - Irritation of skin and dermatitis.

CHRONIC - Repeated overexposure will cause severe skin irritation, dermatitis and sensitization. Sensitized persons may experience rapid irritation of skin upon exposure.

Persons with lung disorders or who are sensitized should not use this product.

Carcinogenicity:	NTP?	IARC Monographs?	OSHA Regulated?
	NO	NO	NO

Medical Conditions Generally Aggravated by Exposure

Allergy, skin disorders

Emergency and First Aid Procedures

EYES - Flush with water, holding lids open for 15 minutes or more. Call physician for advice if necessary.

SKIN - PROMPTLY wash with soap and water. DO NOT wash with solvents. Seek medical advice if irritation develops or persists.

INHALATION - Move person to fresh air if effects occur. If needed, give oxygen or artificial respiration to improve breathing. Consult physician.

INGESTION - Get medical attention immediately. Never give liquids to an unconscious or convulsing person.

**SECTION VII - CONTROL MEASURES**

Respiratory Protection (Specify Type)

Provide adequate exhaust ventilation; use a NIOSH approved respirator if PELS/TLVS are exceeded.

Ventilation	Local Exhaust	If needed.	Special	None known.
	Mechanical	Adequate exhaust ventilation must exhaust AWAY from applicator.		

Protective Gloves	Natural rubber or Neoprene.	Eye Protection	Splash goggles or face shield.
-------------------	-----------------------------	----------------	--------------------------------

Other Protective Clothing or Equipment

Use rubber apron, face shield and appropriate clothing to prevent contact with skin. Launder contaminated clothing before reuse. Discard contaminated leather shoes and canvas sneakers. Protective skin creams help cleaning with soap and water, but gloves must still be worn. An eye wash station or an adequate supply of clean water must be available at work area.

Work/Hygienic Practices Enforce careful handling to prevent splashing. Wash thoroughly after use.

**SECTION VIII - PRECAUTIONS FOR SAFE HANDLING AND USE**

Steps to be Taken in Case Material is Released or Spilled

Wear protective equipment to prevent exposure. Stop spill and dike to prevent spreading. Cover spill with absorbent materials and collect into containers. Clean contaminated area with detergent and water or a steam cleaner for best results.

Waste Disposal Method

Dispose in accordance with Federal, State and Local requirements.

Precautions to be Taken in Handling and Storing

Keep containers tightly closed when not in use.

Other Precautions NONE KNOWN.

Prepared by Samet Dy - Chemist

**PLEASE NOTE** "The above information is accurate to the best of our knowledge. However, since data, safety standards, and government regulations are subject to change and the conditions of handling and use, or misuse, are beyond our control, Dur-A-Flex, Inc. MAKES NO WARRANTY, EITHER EXPRESS OR IMPLIED, WITH RESPECT TO THE COMPLETENESS OR CONTINUING ACCURACY OF THE INFORMATION CONTAINED HEREIN AND DISCLAIMS ALL LIABILITY FOR RELIANCE THEREON. User should satisfy himself that he has all current data relevant to his particular use."

## **DUR-A-CRETE**

### **DESCRIPTION**

DUR-A-CRETE is a heavy duty, trowel applied, seamless floor topping comprised of specially formulated two component, 100% solids epoxy resins and select graded colored sand aggregate. It is designed to repair deteriorated floors and to protect new floors from chemical deterioration and industrial abuse. DUR-A-CRETE adheres tenaciously to properly prepared concrete, quarry tile, ceramic tile and brick pavers. A seamless, sanitary, cove base can be incorporated into this system.

### **BENEFITS**

- Fills and Levels Deteriorated Substrates
- Long Working Time
- Easy to Trowel
- No Odor
- Can Be Non-Skid or Smooth Texture

### **COLORS**

DUR-A-CRETE is natural but is available in 15 standard colors when mixed with SHOP-FLOOR liquids. Please refer to the Standard Color Chart on our website. Custom colors are available upon request.

### **TYPICAL USES**

DUR-A-CRETE is ideally suited for use where OSHA, USDA, and EPA standards must be met. Such as:

- Machine Shops
- Loading Docks
- Traffic Aisles
- Ramps
- Heavy Manufacturing Areas
- Spalled Joint Repair

### **SURFACE PREPARATION**

This product requires preparation in order to perform as expected. Substrate must be roughened, clean, sound, and dry. Please refer to the master Surface Preparation Guide on our website for more information.

### **APPLICATION METHOD**

DUR-A-CRETE is always hand or power troweled into a wet primer of DUR-A-GLAZE #4. It is customarily applied at 1/4" thickness but can be applied as thick as necessary to fill and level an eroded or spalled concrete floor.

### **LIMITATIONS**

This product is best suited for application in temperatures between 55°F and 95°F. Substrate must be clean, sound, and dry.

### **PACKAGING**

DUR-A-CRETE hardener and resin is available in 1-gallon cans, 5-gallon pails, and 50-gallon drums. DUR-A-GLAZE #4 is available in 1-gallon cans, 5-gallon pails and 50-gallon drums. DUR-A-CRETE TROWEL MIX aggregate is available in 40 lb bags.

### **CHEMICAL RESISTANCE**

This product is resistant to many common chemicals. Please refer to the master Chemical Resistance Chart on our website for actual resistance to specific chemicals/reagents.

### **GUIDE SPECIFICATIONS**

This product is part of the DUR-A-FLEX family of polymer systems. Please contact DUR-A-FLEX for complete three part guide specs.

### **CLEANING**

This product is considered a low maintenance flooring solution; however, certain textures and service environments do require certain procedures. Please refer to the master Cleaning Guide on our website.

### **JOINT GUIDELINES**

Refer to the Joint Guidelines for complete details on our website.

# DUR-A-CRETE

## TECHNICAL INFORMATION

<b>Physical Property</b>	<b>Test Method</b>	<b>Result</b>
Hardness (Shore D)	ASTM D-2240	80
Compressive Strength	ASTM D-695 ASTM C-579	17,500 psi 12,500 psi
Tensile Strength	ASTM D-638 ASTM C-307	2,500 psi 1,800 psi
Tensile Elongation	ASTM D-638	7.00%
Flexural Strength	ASTM D-790 ASTM C-580	(C-293) 5,900 psi 4,200 psi
Flexural Modulus of Elasticity	ASTM D-790	$6.0 \times 10^5$
Coefficient of Linear Expansion	ASTM D-696	$2 \times 10^{-5}$
Bond Strength to Concrete	ASTM D-4541	400 psi substrate fails
Indentation	ML D-3134	No indentation
Impact Resistance	ML D-3134	Pass
Water Absorption	ASTM D-570	0.04%
Heat Resistance Limitation		140°F – 200°F
Flammability	ASTM D-635	Self Extinguishing
Flame Spread/NFPA 101	ASTM E-84	Class A
Abrasion Resistance CS17 Wheel 1000 GM Load 1000 Cycles	ASTM D-4060	18 mg loss
Coefficient of Friction Standard Slip-Resistant Orange Peel Smooth	ASTM D-2047	0.95 Unsealed 0.8 0.7
VOC Content		0 g/l

### SPECIAL PURPOSES FORMULA

**DUR-A-GLAZE #4 “Regular”** – For most typical installations under normal conditions.

**DUR-A-GLAZE #4 “Cold Cure”** - For cold area applications when temperature cannot be maintained over 50°F, and when a more rapid cure is required at normal temperatures. This will amber as a top coat.

**DUR-A-GLAZE #4 “Fast”** – Use for intermediate coats in room temperature areas where fast turnaround is desired.

**DUR-A-GLAZE #4 “Water Clear”** - Ideal for topcoating quartz floors. Has excellent color retention. May be used in warm temperatures when longer pot life is required.

**DUR-A-GLAZE #4 “Damp Primer”** - For use as a Prime Coat or a Base Coat on new concrete (28 to 120 days old) or freshly acid etched concrete, or when a surface cannot be dried thoroughly.

**DUR-A-GLAZE #4 “KF”** – For areas where thermal cycling from 32°F to 200°F and exposure to food spillage is expected. Contains Bio-Pruf®.

**DUR-A-GLAZE Novolac** – For areas with exposure to high heat and/or high concentrations of acid or alkali.

### DRAWINGS AND DETAILS

Standard CAD drawings and details are available for coves, drains, breaches, transitions, etc. Please contact DUR-A-FLEX for actual drawings.

### MOISTURE CONCERNS

Please refer to the Floor Evaluation Flow Chart in the Contractor’s Center of our website for a step-by-step process to determine the condition of the concrete.

### CAUTION

**Follow the Hazardous Materials Identification System labeling guide for proper personal protective equipment to use when handling this product. Use only as directed. KEEP OUT OF REACH OF CHILDREN.**

*Before using any DUR-A-FLEX, Inc. product, be sure the Material Safety Data Sheet is read and understood.*

## DUR-A-CRETE

**IMPORTANT!** Read these instructions carefully several days prior to starting your work. Seek answers to any questions you may have before you begin. DUR-A-FLEX, Inc. maintains a Technical Staff that will be glad to answer your questions and give you advice pertaining to your particular installation. DUR-A-FLEX Power Mixers are highly recommended for mixing this 100% solids heavy-duty resurfacer. Material for cove or for small areas can be mixed with a 1/2" - 3/4" heavy duty, slow speed, electric drill equipped with a DUR-A-FLEX bird cage mixing attachment and a 5-gallon metal pail. Large areas will require two or more Power Mixers, or a large mortar mixer. **NOTE:** Cement mixers will not work.

### **DUR-A-CRETE is applied by "trowel method".**

DUR-A-CRETE is typically applied at thicknesses ranging from 3/16" to 1/4". DUR-A-CRETE can also be used to form containment berms or to slope floor to drain. At thicknesses greater than 1/2", clean, dry 3/8" peastone can be added to DUR-A-CRETE mortar mix to extend coverage rate.

### **SURFACE PREPARATION**

Surface must be clean, sound, dry and free of all oil, grease, detergent film, sealers and/or curing compounds. A surface profile of 10 to 15 mils is appropriate for most applications. Please refer to the DUR-A-FLEX Surface Preparation Guide on our website for detailed instructions.

### **MIXING AREA**

Select a convenient mix area and protect the surface from spillage by covering with a layer of cardboard and/or a sheet of plastic. Be generous with the amount of space you allocate for this function. The more comfortably your mixer works, the less likely you are to have a "mix error". Make ready all necessary tools, mix and measure containers, etc. **DO NOT MIX UNTIL READY FOR IMMEDIATE USE.** To obtain neat, straight, chip resistant edges at termination points and/or drains, a "keyed edge" must be installed.

### **PRIMING**

Prime all surfaces with 100% solids DUR-A-GLAZE #4 as soon as the surface has been prepared. On oily concrete slabs HI-SPEED Detergent/Degreaser is recommended, be sure to apply primer **before** oil has a chance to "wick" up to the top of the slab and migrate across the surface.

### **TROWEL APPLICATION**

- A. Prepare the surface as outlined in the Surface Preparation Guide.
- B. Prime the prepared area (or section) by applying a coat of DUR-A-GLAZE #4 at approximately 150-200 Sq Ft per gallon. Apply DUR-A-CRETE while Primer is still wet or tacky. If the primer cures "tack free" before the area is resurfaced, the area must be primed again.
- C. Mix DUR-A-CRETE epoxy mortar:
  1. Pour 24 **Fluid** oz. of DUR-A-GLAZE #4 (or one part) hardener into a bucket then add 48 **Fluid** oz. of SHOP FLOOR or DUR-A-GLAZE #4 (or two parts) resin. Mix with Jiffler type mixer for 2 minutes.
  2. Move the paddle back and forth scraping the bottom and sides of the pail while mixing. This is very important! THOROUGH BLENDING IS MANDATORY.
  3. Slowly add 1 bag of DUR-A-CRETE Aggregate. Allow the mixer to run for another minute. Warmer aggregate and epoxy blends set faster than cooler components. A properly mixed batch trowels easier and has a uniform surface appearance. Incomplete mixing will cause an inconsistent finish.
- D. Place the entire batch of mortar on the floor. Spread at a desired thickness with a screed box or gage rake.

- E. Finish smooth with a small hand or power trowel. Apply sufficient pressure on the trowel to compact the DUR-A-CRETE as much as possible. If the mortar “pulls” creating a rough surface, the trowel has become sticky or it is positioned improperly. Spray Trowel-Eeze on trowel to help close DUR-A-CRETE mortar properly and reduce porosity. The finished surface will follow the contour of the concrete substrate. Cracks and holes should be pre-filled with DUR-A-CRETE mortar before troweling overlayment. A bright light behind the applicator will reveal trowel marks readily.
- F. Trowel must be kept clean with a lubricant such as Trowel-Eeze. If solvent odor cannot be tolerated, a soapy steel wool pad will help keep trowel clean. In either case, the trowel must be wiped before using on the DUR-A-CRETE. Check for 1/4” thickness frequently. Allow to fully cure. **NOTE:** It is essential to keep moisture from contacting DUR-A-CRETE during installation and curing time. All plumbing leaks must be stopped or diverted prior to commencement of work.

**IMPORTANT!** Mix only what can be placed in 10 - 15 minutes. Never attempt to re-temper the mortar after it begins to set.

### **GRIND FLOOR**

The purpose of grinding is to remove trowel marks and to smooth the surface prior to applying grout coats, topcoats, etc. Grout coats can usually be omitted if the topping is to be finished with a SHOP FLOOR or DUR-A-QUARTZ system. The best method of grinding is to use an EDCO floor grinder with carborundum stones. It is important to grind floor moving east to west and north to south for best results. On small areas and in tight places, rub by hand with carborundum stones. Remove all sanding debris and dust with a vacuum cleaner, sweeping is not acceptable. A 3M dust mask should be worn while grinding the floor.

### **TOPCOAT APPLICATION**

Appearance, texture and the type of traffic or chemical abuse the floor receives will determine what type of topcoat should be applied. Consult DUR-A-FLEX, Inc. for technical assistance to determine whether to use DUR-A-GLAZE #4, NOVOLAC, CRETE-GARD, etc.

### **TYPICAL DUR-A-CRETE TOPCOAT**

1. Combine 1 part CRETE-GARD hardener with 2 parts DUR-A-GARD RESIN by volume. Using a Jiffler type mixer, mix thoroughly for 3 minutes. Mix only what can be used within 5 - 10 minutes. Refer to the appropriate Product Data Sheet for Pot Life of individual hardener.
2. Apply combined epoxy with a 12” Q-28 squeegee (window type). A 10” or 12” handle can be added to the squeegee to extend reach. The paint roller should have a long (5’) handle. Pour a 4”- 6” ribbon of blended epoxy on the floor. Bend forward and spread the epoxy by moving the squeegee in a continuous semi-circular movement from left to right to left, etc. Simultaneously moving backward slowly and pulling the epoxy with you. Pull the blended epoxy over the same area twice to force epoxy into DUR-A-CRETE mortar. Move squeegee slowly and apply sufficient pressure to obtain a uniform appearance. Avoid leaving puddles and squeegee marks. Then walk onto the surface with spiked golf shoes and back roll the applied area with a 3/8” non-shed roller. Cross roll area perpendicular to backrolling direction to achieve an orange peel appearance.

### **ADDITIONAL TOPCOAT OR FLOOR SYSTEM**

Follow the Application Instructions for the product selected. See POLY-THANE, DUR-A-GARD, SHOP FLOOR or DUR-A-QUARTZ Application Instructions.

### **CAUTION**

**Follow the Hazardous Materials Identification System labeling guide for proper personal protective equipment to use when handling this product. Use only as directed. KEEP OUT OF REACH OF CHILDREN.**

### **JOINT GUIDELINES**

Refer to the Joint Guidelines for complete details on our website.

***Before using any DUR-A-FLEX, Inc. product, be sure the Material Safety Data Sheet is read and understood.***

## DUR-A-GARD

### DESCRIPTION

DUR-A-GARD Epoxy Coating is a pigmented, two component, low odor, 100% solids, thermosetting epoxy designed especially for flooring applications subjected to moderate traffic and chemicals. DUR-A-GARD Epoxy Coating is ideally suited for application on concrete. This coating is extremely durable, sanitary and easy to clean.

### BENEFITS

- Stain Resistant
- Durable
- Easy to Clean
- Good Color Stability

### COLORS

Dur-A-Gard is available in 15 standard colors. Please refer to the Standard Color Chart on our website. Custom colors are available upon request.

### TYPICAL USES

- Laboratories
- Hospitals
- Garages
- Laundries
- Pharmaceutical Plants
- Clean Rooms

### PACKAGING

DUR-A-GARD Epoxy Coating is packaged in 1-gallon cans, 5-gallon pails and 50-gallon drums. Shelf life is one year in unopened containers.

### CHEMICAL RESISTANCE

This product is resistant to most common chemicals. Please refer to the master Chemical Resistance Chart on our website for actual resistance to specific chemicals/reagents.

### SURFACE PREPARATION

This product requires preparation in order to perform as expected. Substrate must be profiled, clean, sound, and dry. Substrate must be primed with DUR-A-SHIELD, DUR-A-GLAZE WB, or DUR-A-GLAZE TIE-COAT. Please refer to the master Surface Preparation Guide on our website for more information.

### APPLICATION METHOD /SPREAD RATES

See DUR-A-GARD Application Instruction Sheet on our website for complete instructions.

### LIMITATIONS

This product is best suited for application in temperatures between 60°F and 90°F. Substrate must be clean, sound, and dry. Excess of 30 mils may result in bubbles and or pinholes in the coating.

### CLEANING

This product is considered to be a low maintenance flooring solution, however, certain textures and service environments require specific procedures. Please refer to the master Cleaning Guide on our website.

### “SPECIAL PURPOSE” FORMULATIONS

1. **DUR-A-GARD "Regular"** has good color stability and a fairly low viscosity so it is easy to apply. However, it is very sensitive to water and moisture during its curing period. The surface must be perfectly dry during application.
2. **DUR-A-GARD "Fast"** is a fast curing hardener designed for fast curing intermediate coats.
3. **DUR-A-GARD "OPF"** is designed to be used as the first and / or second topcoat to yield a uniform "orange peel" finish.
4. **CRETE-GARD** is designed as a topcoat for DUR-A-CRETE, and to achieve a heavy orange peel texture.

# DUR-A-GARD

## TECHNICAL INFORMATION

Mix Ratio (by volume)	1 Part Hardener to 2 Parts Resin
Viscosity at 70° F	700 cps
Pot life at 70° F	20 Minutes Regular Hardener 13 Minutes Fast Hardener
Cure Time, Touch Dry at 70° F	6 -8 Hours
Cured Film Thickness	16 Mils at 100 Sq. Ft. / Gallon Spread Rate
Toxicity	Non – Toxic, USDA Approved

Physical Property	Test Method	Result
Hardness (Shore D)	ASTM D-2240	70-80
Compressive Strength	ASTM D-695 ASTM C-579	16,000 psi 10,500 psi
Tensile Strength	ASTM D-638 ASTM C-307	3,000 psi 1,950 psi
Tensile Elongation	ASTM D-638	7.50%
Flexural Strength	ASTM D-790 ASTM C-580	4,000 psi 2,900 psi
Flexural Modulus of Elasticity	ASTM D-790	$5.5 \times 10^5$
Linear Expansion	ASTM D-696	$2 \times 10^{-5}$
Bond Strength to Concrete	ASTM D-4541	400 psi substrate fails
Indentation	MIL D-3134	.025 MAX
Impact Resistance	MIL D-3134	Pass
Water Absorption	ASTM D-570	0.04%
Heat Resistance Limitation		140°F - 200°F
Flammability	ASTM D-635	Self Extinguishing
Flame Spread/NFPA 101	ASTM E-84	Class A
Abrasion Resistance CS17 Wheel 1000 GM Load 1000 Cycles	ASTM D-4060	35 mg loss
Coefficient of Friction Orange Peel Smooth	ASTM D-2047	0.8 0.7
VOC Content		Regular, Fast, Crete Gard = 4 g/l Dur-A-Gard OPF = 59 g/l

### DRAWINGS AND DETAILS

Standard CAD drawings and details are available for coves, drains, breaches, transitions, etc.

### MOISTURE CONCERNS

Please refer to the Floor Evaluation Flow Chart in the Contractor's Center of our website for a step-by-step process to determine the condition of the concrete.

### JOINT GUIDELINES

Refer to the Joint Guidelines for complete details on our website.

### GUIDE SPECIFICATIONS

This product is part of the DUR-A-FLEX family of polymer systems. Please contact DUR-A-FLEX for complete three part guide specs.

### CAUTION

Slight lot-to-lot color variations may occur. When ordering to match a previous color, inquire if the same lot number or quality control number is still available. **Follow the Hazardous Materials Identification System labeling guide for proper personal protective equipment to use when handling this product. Use only as directed. KEEP OUT OF REACH OF CHILDREN.**

*Before using any DUR-A-FLEX, Inc. product, be sure the Material Safety Data Sheet is read and understood.*



**DUR-A-FLEX**  
INNOVATION FROM THE FLOOR UP

95 Goodwin Street, East Hartford, CT., 06108 (860) 528-9838

# Material Safety Data Sheet

Date Prepared 8/2/2010

<b>SECTION I - IDENTIFICATION</b>	<b>HAZARD RATING</b> 0 = Least 1 = Slight 2 = Moderate 3 = High 4 = Extreme	Health	3
		Flammability	0
		Reactivity	0
		Personal Protection	F
<b>IDENTITY (As Used on Label)</b>	<b>Dur-A-Crete Aggregate</b>		
<b>COMMON NAME</b>	Natural Aggregates Blend		

<b>SECTION II - PRODUCT COMPONENTS</b>	<b>CAS.#</b>	<b>OSHA PEL</b>	<b>ACGIH TLV</b>
Crystalline Silica (Quartz) <sup>1</sup>	14808-60-7	<u>10mg/m<sup>3</sup></u>	0.1 mg/m <sup>3</sup>
		%SiO <sub>2</sub> +2	

<sup>1</sup>Crystalline silica can be a lung injury and cancer hazard. Do not breathe dust. May cause delayed lung injury. Long term exposure can cause silicosis, a respiratory disease which can result in a delayed, disabling, and sometimes fatal lung injury. Crystalline silica inhaled from occupational sources can cause cancer in humans. Risk of injury is dependent on the duration and level of exposure. A single exposure will not result in serious and adverse effects.

T.S.C.A. Status - O.K. on all above components.

**\*FOR SPILL, LEAK, FIRE, OR ACCIDENT, CALL CHEMTREC 24-HOUR EMERGENCY NUMBER 1-800-424-9300\***

## SECTION III - PHYSICAL/CHEMICAL CHARACTERISTICS

Boiling Point	4,000F	Specific Gravity (H <sub>2</sub> O = 1)	>1
Vapor Pressure (mm Hg)	N/A	Melting Point	3,000F
Vapor Density (AIR = 1)	N/A	Evaporation rate (Butyl Acetate = 1)	N/A
Volatile Organic Compounds (VOC) = Zero grams/liter			
Solubility in Water	Insoluble		
Appearance and Odor	Natural Aggregate. No odor.		

## SECTION IV - FIRE and EXPLOSION HAZARD DATA

Flash Point (Closed Cup Method)	N/A	Flammable Limits	LEL	UEL
			N/A	N/A
Extinguishing Media	N/A			
Special Firefighting Procedures	N/A			
Unusual Fire and Explosion Hazards	N/A			

## SECTION V - REACTIVITY DATA

Stability	Unstable	Conditions to Avoid
	Stable	X NONE KNOWN
Incompatibility (Materials to Avoid)	Hydrofluoric acid and powerful oxidizing agents.	
Hazardous Decomposition or Byproducts	NONE KNOWN	
Hazardous Polymerization	May Occur	Conditions to Avoid
	Will Not Occur	X NONE KNOWN

## SECTION VI - HEALTH HAZARD DATA

Route(s) of Entry:	Inhalation?	Skin?	Ingestion?
	Yes	YES	YES

Signs and Symptoms of Exposure Shortness of breath and reduced pulmonary function.

Health Hazards (Acute and Chronic) Note: Persons with lung disorders or who are sensitized should not use this product.

ACUTE - No symptoms

CHRONIC - excessive inhalation of dust may result in respiratory disease such as silicosis, pulmonary fibrosis, etc. The IARC has evaluated in Vol. 42 (monographs) that there is "sufficient evidence for the carcinogenicity of crystalline silica dust to experimental animals" and "limited evidence" with respect to humans.

Carcinogenicity:	NTP?	IARC Monographs?	OSHA Regulated?
	Yes (Respirable Quartz)	Yes * Level 2A Grouping	No

Medical Conditions Generally Aggravated by Exposure  
Lung disorders and persons subject to eye irritation.

### Emergency and First Aid Procedures

EYES - Flush with water, holding lids open for 15 minutes or more. Call physician for advice if necessary.

SKIN - PROMPTLY wash with soap and water. DO NOT wash with solvents. Seek medical advice if irritation develops or persists.

INHALATION - Move person to fresh area if effects occur. If needed, give oxygen or artificial respiration to improve breathing. Consult physician.

INGESTION - Expected to be slightly toxic by ingestion. If swallowed, induce vomiting immediately as directed by a physician.

Get medical attention immediately. Never give liquids to an unconscious or convulsing person.

OTHER HEALTH EFFECTS - Medical conditions which may be aggravated by exposure to this product include, conjunctivitis of the eye, dermatitis of the skin, asthma and respiratory diseases. Sensitization may occur by skin contact.

**\*\*NOTE\*\*** persons with lung disorders or who are sensitized should not use this product.

## SECTION VII - CONTROL MEASURES

Respiratory Protection (Specify Type): Atmospheric levels should be maintained below the exposure limits listed in section II by using engineering controls. Provide adequate exhaust ventilation and/or NIOSH approved cartridge respirator.

Ventilation	Local Exhaust	If needed.	Special	None Known.
	Mechanical	Adequate exhaust ventilation must exhaust AWAY from applicator.		

Protective Gloves	Natural rubber or Neoprene.	Eye Protection	Splash goggles or face shield.
-------------------	-----------------------------	----------------	--------------------------------

### Other Protective Clothing or Equipment

Use adequate ventilation and dust collection. To minimize exposure, wear a respirator approved for silica dust when using, handling, storing or disposing of this product. Refer to the most recent standards of ANSI (Z88.2), OSHA (29 CFR 1910.134), MSHA (30 CFR Parts 56 and 57), and NIOSH Respirator Decision Logic. Maintain, clean and fit test respirators in accordance with OSHA regulations.

Work/Hygienic Practices Avoid creating and breathing dust.

## SECTION VIII - PRECAUTIONS FOR SAFE HANDLING AND USE

### Steps to be Taken in Case Material is Released or Spilled

Do not breathe dust. Do not rely on your sight to determine if dust is in the air. Silica may be in the air without a visible dust cloud. Avoid creation of respirable dust

### Waste Disposal Method:

Dispose in accordance with Federal, State and Local requirements.

Avoid creation of respirable dust. Take precaution against bag breakage

Other Precautions NONE KNOWN.

Prepared By: Samet Dy -Chemist

**PLEASE NOTE** "The above information is accurate to the best of our knowledge. However, since data, safety standards, and government regulations are subject to change and the conditions of handling and use, or misuse, are beyond our control, Dur-A-Flex, Inc. MAKES NO WARRANTY, EITHER EXPRESS OR IMPLIED, WITH RESPECT TO THE COMPLETENESS OR CONTINUING ACCURACY OF THE INFORMATION CONTAINED HEREIN AND DISCLAIMS ALL LIABILITY FOR RELIANCE THEREON. User should satisfy himself that he has all current data relevant to his particular use."



95 Goodwin Street, East Hartford, CT., 06108 (860) 528-9838

# Material Safety Data Sheet

Date Prepared 8/2/2010

<b>SECTION I - IDENTIFICATION</b>	HAZARD RATING	Health	3
	0 = Least	Flammability	1
	1 = Slight 2 = Moderate 3 = High 4 = Extreme	Reactivity	0
		Personal Protection	G
IDENTITY (As Used on Label)	<b>Dur-A-Glaze #4 Hardener: Regular, Fast, Cold Cure, CR4, Damp-Primer, Water Clear</b>		
COMMON NAME	Epoxy Resin Curatives		

SECTION II - PRODUCT COMPONENTS	CAS.#	OSHA PEL	ACGIH TLV
Benzyl Alcohol	100-51-6	N.E. <sup>1</sup>	N.E.
3, Aminomethyl -3,5,5-Trimethyl	2855-13-2	N.E.	N.E.
1, 5 Pentanediamine, 2 Methyl	15520-10-2	N.E.	N.E.
N, Aminoethyl Piperazine	140-31-8	N.E.	N.E.
Diglycidyl Ether Bisphenol A Epoxy Resin	25085-99-8	N.E.	N.E.
Salicylic Acid	69-72-7	N.E.	N.E.
1, 5 Pentanediamine, 2 Methyl	15520-10-2	N.E.	N.E.
Benzene-1,3-Dimethaneamine	1477-550	N.E.	N.E.
Phenol	108-95-2	N.E.	N.E.
Triphenyl phosphite	101-02-0	N.E.	N.E.

<sup>1</sup>None Established

T.S.C.A. Status - O.K. on all above components.  
**\*FOR SPILL, LEAK, FIRE, OR ACCIDENT, CALL CHEMTREC 24-HOUR EMERGENCY NUMBER 1-800-424-9300\***

### SECTION III - PHYSICAL/CHEMICAL CHARACTERISTICS

Boiling Point	485°F	Specific Gravity (H2O = 1)	<1
Vapor Pressure (mm Hg)	0.02	Melting Point	N/A
Vapor Density (AIR = 1)	N/A	Evaporation rate (Butyl Acetate = 1)	N/A
Volatile Organic Compounds (VOC)	0 g/l		
Solubility in Water	Partially soluble.		
Appearance and Odor	Pale yellow colored liquid. Amine odor.		

### SECTION IV - FIRE and EXPLOSION HAZARD DATA

Flash Point (Closed Cup Method)	220°F	Flammable Limits	LEL	UEL
			N/A	N/A
Extinguishing Media	Dry chemicals, carbon dioxide, foam, water spray.			
Special Firefighting Procedures	Firefighters should wear full emergency equipment with self-contained breathing apparatus. Irritating gases may be generated by fire.			
Unusual Fire and Explosion Hazards	Cool exposed containers with cold water spray to prevent pressure buildup that may rupture the containers.			

### SECTION V - REACTIVITY DATA

Stability	Unstable		Conditions to Avoid
	Stable	X	Keep container closed when not in use.
Incompatibility (Materials to Avoid)	Strong oxidizers and acids.		
Hazardous Decomposition or Byproducts	By Fire- carbon monoxide, carbon dioxide, aldehydes, nitrogen.		
Hazardous Polymerization	May Occur		Conditions to Avoid Uncontrolled reaction with epoxy resins. Avoid breathing fumes generated by hardener and epoxy mixture when not used within established pot life.
	Will Not Occur	X	

**SECTION VI - HEALTH HAZARD DATA**

Route(s) of Entry:	Inhalation?	Skin?	Ingestion?
	YES	YES	YES

Signs and Symptoms of Exposure      Irritation on skin.

Health Hazards (Acute and Chronic)

Note: Persons with lung disorders or who are sensitized should not use this product.

ACUTE - Irritation on skin and dermatitis.

CHRONIC - Repeated overexposure will cause severe skin irritation, dermatitis and sensitization.

Sensitized persons may experience rapid irritation of skin upon exposure.

Carcinogenicity:	NTP?	IARC Monographs?	OSHA Regulated?
	NO	NO	NO

Medical Conditions Generally Aggravated by Exposure

Allergy, skin disorders.

Emergency and First Aid Procedures

EYES - Flush with water, holding lids open for 15 minutes or more. Call physician for advice if necessary.

SKIN - PROMPTLY wash with soap and water. DO NOT wash with solvents. Seek medical advice if irritation develops or persists.

INHALATION - Move person to fresh air if effects occur. If needed, give oxygen or artificial respiration to improve breathing. Consult physician.

INGESTION - Get medical attention immediately. Never give liquids to an unconscious or convulsing person.

**SECTION VII - CONTROL MEASURES**

Respiratory Protection (Specify Type)

Provide adequate exhaust ventilation; use a NIOSH approved respirator if PELs/TLVs are exceeded.

Ventilation	Local Exhaust	If needed.	Special	None known.
	Mechanical	Adequate exhaust ventilation must exhaust AWAY from applicator.		

Protective Gloves	Natural or Neoprene gloves.	Eye Protection	Splash goggles or face shield.
-------------------	-----------------------------	----------------	--------------------------------

Other Protective Clothing or Equipment

Use rubber apron, face shield and appropriate clothing to prevent contact with skin. Launder contaminated clothing before reuse. Discard contaminated leather shoes and canvas sneakers. Protective skin creams help cleaning with soap and water, gloves must be still be worn. An eye wash station or an adequate supply of clean water must be available at work area.

Work/Hygienic Practices      Enforce careful handling to prevent splashing. Wash thoroughly after use.

**SECTION VIII - PRECAUTIONS FOR SAFE HANDLING AND USE**

Steps to be Taken in Case Material is Released or Spilled

Wear protective equipment to prevent exposure. Stop spill and dike to prevent spreading. Cover spill with absorbent materials and collect into containers. Clean contaminated area with detergent and water or a steam cleaner for best results.

Waste Disposal Method

Dispose in accordance with Federal, State, and Local requirements.

Precautions to be Taken in Handling and Storing

Keep containers tightly closed when not in use.

Other Precautions      NONE KNOWN.

Prepared by      Samet Dy - Chemist

**PLEASE NOTE** "The above information is accurate to the best of our knowledge. However, since data, safety standards, and government regulations are subject to change and the conditions of handling and use, or misuse, are beyond our control, Dur-A-Flex, Inc. MAKES NO WARRANTY, EITHER EXPRESS OR IMPLIED, WITH RESPECT TO THE COMPLETENESS OR CONTINUING ACCURACY OF THE INFORMATION CONTAINED HEREIN AND DISCLAIMS ALL LIABILITY FOR RELIANCE THEREON. User should satisfy himself that he has all current data relevant to his particular use."



**DUR-A-FLEX**  
INNOVATION FROM THE FLOOR UP

95 Goodwin Street, East Hartford, CT., 06108 (860) 528-9838

# Material Safety Data Sheet

Date Prepared 8/2/2010

<b>SECTION I - IDENTIFICATION</b>	HAZARD RATING 0 = Least 1 = Slight 2 = Moderate 3 = High 4 = Extreme	Health	1
		Flammability	1
		Reactivity	0
		Personal Protection	G
IDENTITY (As Used on Label) <b>Dur-A-Glaze #4 RESIN/ Bio-Pruf®</b>			
COMMON NAME Epoxy Resin			

SECTION II - PRODUCT COMPONENTS	CAS.#	OSHA PEL	ACGIH TLV
Diglycidyl Ether Bisphenol A Epoxy Resin	25085-99-8	N.E. <sup>1</sup>	N.E.
Aliphatic Glycidyl Ether Diluent	68609-97-2	N.E.	N.E.
Film Additives	Proprietary <sup>2</sup>	N.E.	N.E.

<sup>1</sup>Not Established

<sup>2</sup>The manufacturer of these component states that they will provide additional information to a health professional in the event of an emergency.

T.S.C.A. Status - O.K. on all above components.

**\*FOR SPILL, LEAK, FIRE, OR ACCIDENT, CALL CHEMTREC 24-HOUR EMERGENCY NUMBER 1-800-424-9300\***

### SECTION III - PHYSICAL/CHEMICAL CHARACTERISTICS

Boiling Point	N/A	Specific Gravity (H2O = 1)	>1
Vapor Pressure (mm Hg)	N/A	Melting Point	N/A
Vapor Density (AIR = 1)	N/A	Evaporation rate (Butyl Acetate = 1)	N/A
Volatile Organic Compounds (VOC)	0 g/L		
Solubility in Water	None		
Appearance and Odor	Viscous liquid. Mild characteristic odor.		

### SECTION IV - FIRE and EXPLOSION HAZARD DATA

Flash Point (Closed Cup Method)	485°F	Flammable Limits	LEL	UEL
			N/A	N/A

Extinguishing Media Foam, CO<sub>2</sub>, Dry Chemical, Water Spray.

Special Firefighting Procedures

Firefighters should wear full emergency equipment with self-contained breathing apparatus.

Unusual Fire and Explosion Hazards

Cool fire - exposed containers with cold water spray to prevent pressure build - up that may rupture the container. Combustion products may be toxic.

### SECTION V - REACTIVITY DATA

Stability	Unstable		Conditions to Avoid
	Stable	X	Excess heating over long periods of time degrades the resin.

Incompatibility (Materials to Avoid) Uncontrolled reaction with amines.

Hazardous Decomposition or Byproducts Fire- Carbon Monoxide, Carbon Dioxide, Nitrogen Oxide, Aldehydes.

Hazardous Polymerization	May Occur		Conditions to Avoid
	Will Not Occur	X	Uncontrolled reaction with amines.

## SECTION VI - HEALTH HAZARD DATA

Route(s) of Entry:	Inhalation?	Skin?	Ingestion?
	YES	YES	YES
Signs and Symptoms of Exposure	Irritation on skin.		
Health Hazards (Acute and Chronic)			
ACUTE - Irritation on skin and dermatitis.			
CHRONIC - Repeated overexposure will cause severe skin irritation, dermatitis and sensitization. Sensitized persons may experience rapid irritation of skin upon exposure.			

Carcinogenicity:	NTP?	IARC Monographs?	OSHA Regulated?
	NO	NO	NO

Medical Conditions Generally Aggravated by Exposure  
Allergy, skin disorders.

Emergency and First Aid Procedures

EYES - Flush with water, holding lids open for 15 minutes or more. Call physician for advice if necessary.

SKIN - PROMPTLY wash with soap and water. DO NOT wash with solvents. Seek medical advice if irritation develops or persists.

INHALATION - Move person to fresh air if effects occur. If needed, give oxygen or artificial respiration to improve breathing. Consult physician.

INGESTION - Get medical attention immediately. Never give liquids to an unconscious or convulsing person.

Note: Persons with lung disorders or who are sensitized should not use this product.

## SECTION VII - CONTROL MEASURES

Respiratory Protection (Specify Type)

Provide adequate exhaust ventilation; use a NIOSH - approved respirator if PELS/TLVS are exceeded.

Ventilation	Local Exhaust	If needed.	Special	None known.
	Mechanical	Adequate exhaust ventilation must exhaust AWAY from applicator.		

Protective Gloves	Natural or Neoprene gloves.	Eye Protection	Splash goggles or face shield.
-------------------	-----------------------------	----------------	--------------------------------

Other Protective Clothing or Equipment

Use rubber apron, face shield and appropriate clothing to prevent contact with skin. Launder contaminated clothing before reuse. Discard contaminated leather shoes and canvas sneakers. Protective skin creams help cleaning with soap and water, gloves must be still be worn. An eye wash station or an adequate supply of clean water must be available at work area.

Work/Hygienic Practices      Enforce careful handling to prevent splashing. Wash thoroughly after use.

## SECTION VIII - PRECAUTIONS FOR SAFE HANDLING AND USE

Steps to be Taken in Case Material is Released or Spilled

Wear protective equipment to prevent exposure. Stop spill and dike to prevent spreading. Cover spill with absorbent materials and collect into containers. Clean contaminated area with detergent and water or a steam cleaner for best results.

Waste Disposal Method

Dispose in accordance with Federal, State, and Local requirements.

Precautions to be Taken in Handling and Storing

Keep containers tightly closed when not in use.

Other Precautions      NONE KNOWN.

Prepared by      Samet Dy - Chemist

<b>PLEASE NOTE</b>	"The above information is accurate to the best of our knowledge. However, since data, safety standards, and government regulations are subject to change and the conditions of handling and use, or misuse, are beyond our control, Dur-A-Flex, Inc. MAKES NO WARRANTY, EITHER EXPRESS OR IMPLIED, WITH RESPECT TO THE COMPLETENESS OR CONTINUING ACCURACY OF THE INFORMATION CONTAINED HEREIN AND DISCLAIMS ALL LIABILITY FOR RELIANCE THEREON. User should satisfy himself that he has all current data relevant to his particular use."
--------------------	--



95 Goodwin Street, East Hartford, CT., 06108 (860) 528-9838

# Material Safety Data Sheet

Date Prepared 8/2/2010

## SECTION I - IDENTIFICATION

**IDENTITY (As Used on Label)** Shop Floor Resin: all colors

**COMMON NAME** Pigmented Epoxy Resin

HAZARD RATING 0 = Least 1 = Slight 2 = Moderate 3 = High 4 = Extreme	Health	1
	Flammability	1
	Reactivity	0
	Personal Protection	G

## SECTION II - PRODUCT COMPONENTS

	CAS.#	OSHA PEL	ACGIH TLV
Diglycidyl Ether Bisphenol A Epoxy Resin	25068-38-6	N.E. <sup>1</sup>	N.E.
Aliphatic Glycidyl Ether Diluent	68609-97-2	N.E.	N.E.
Titanium Dioxide	13463-67-7	15mg/m <sup>3</sup>	10mg/m <sup>3</sup>
Calcium Carbonate	1317-65-3	15mg/m <sup>3</sup>	10mg/m <sup>3</sup>
Aluminum Silicate	1332-58-7	15mg/m <sup>3</sup>	2mg/m <sup>3</sup>
Barium Sulfate <sup>2</sup>	7727-43-7	10mg/m <sup>3</sup>	10mg/m <sup>3</sup>
Inorganic Iron Oxides	1309-37-1	15mg/m <sup>3</sup>	10mg/m <sup>3</sup>
Chromium(III) Oxide Green(trivalent chromium) <sup>*3</sup>	1308-38-9	1.0mg/m <sup>3</sup>	0.5mg/m <sup>3</sup>

<sup>1</sup>Not Established

<sup>2</sup>Barium Sulfate is listed in SARA III, Part 372, Section 313.

<sup>\*3</sup>This product contains only 1-3ppm (0.0001%-0.0003%) leachable hexavalent chromium. Trivalent chromium is not specifically listed as a possible carcinogen. Only in Dark Green and Light Green pigmented systems.

T.S.C.A. Status - O.K. on all above components.

**\*FOR SPILL, LEAK, FIRE, OR ACCIDENT, CALL CHEMTREC 24-HOUR EMERGENCY NUMBER 1-800-424-9300\***

## SECTION III - PHYSICAL/CHEMICAL CHARACTERISTICS

Boiling Point	N/A	Specific Gravity (H2O = 1)	1.2
Vapor Pressure (mm Hg)	N/A	Melting Point	N/A
Vapor Density (AIR = 1)	N/A	Evaporation rate (Butyl Acetate = 1)	>1
Volatile Organic Compounds	0 g/L		
Solubility in Water	Not Soluble		
Appearance and Odor	Pigmented viscous liquid. Mild characteristic odor.		

## SECTION IV - FIRE and EXPLOSION HAZARD DATA

Flash Point (Closed Cup Method)	485°F	Flammable Limits	LEL	UEL
			N/A	N/A

Extinguishing Media Water spray, Foam, CO<sub>2</sub>, Dry Chemicals.

Special Firefighting Procedures

Wear full protective equipment including self - contained breathing apparatus.

Unusual Fire and Explosion Hazards

Cool storage containers with water spray to prevent pressure build-up that may rupture the containers.

Combustion products may be toxic.

## SECTION V - REACTIVITY DATA

Stability	Unstable		Conditions to Avoid
	Stable	X	Excess heating over long periods of time degrades the resin.

Incompatibility (Materials to Avoid) Uncontrolled reaction with amines.

Hazardous Decomposition or Byproducts By Fire - Carbon monoxide, Carbon dioxide, Nitrogen oxides, Aldehydes.

Hazardous Polymerization	May Occur		Conditions to Avoid
	Will Not Occur	X	Uncontrolled reaction with amines.

**SECTION VI - HEALTH HAZARD DATA**

Route(s) of Entry:	Inhalation?	Skin?	Ingestion?
	YES	YES	YES

Signs and Symptoms of Exposure Irritation of skin.

Health Hazards (Acute and Chronic)

ACUTE - Irritation of skin and dermatitis.

CHRONIC - Repeated overexposure will cause severe skin irritation, dermatitis and sensitization. Sensitized persons may experience rapid irritation of skin upon exposure.

Persons with lung disorders or who are sensitized should not use this product.

Carcinogenicity:	NTP?	IARC Monographs?	OSHA Regulated?
	NO	NO	NO

Medical Conditions Generally Aggravated by Exposure

Allergy, skin disorders.

Emergency and First Aid Procedures

EYES - Flush with water, holding lids open for 15 minutes or more. Call physician for advice if necessary.

SKIN - PROMPTLY wash with soap and water. DO NOT wash with solvents. Seek medical advice if irritation develops or persists.

INHALATION - Move person to fresh air if effects occur. If needed, give oxygen or artificial respiration to improve breathing. Consult physician.

INGESTION - Get medical attention immediately. Never give liquids to an unconscious or convulsing person.

**SECTION VII - CONTROL MEASURES**

Respiratory Protection (Specify Type)

Provide adequate exhaust ventilation; use a NIOSH - approved respirator if PELS/TLVS are exceeded.

Ventilation	Local Exhaust	If needed.	Special	None known.
	Mechanical	Adequate exhaust ventilation must exhaust AWAY from applicator.		

Protective Gloves	Natural rubber or Neoprene.	Eye Protection	Splash goggles or face shield.
-------------------	-----------------------------	----------------	--------------------------------

Other Protective Clothing or Equipment

Use rubber apron, face shield and appropriate clothing to prevent contact with skin. Launder contaminated clothing before reuse. Discard contaminated leather shoes and canvas sneakers. Protective skin creams help cleaning with soap and water, gloves must still be worn. An eye wash station or an adequate supply of clean water must be available at work area.

Work/Hygienic Practices Enforce careful handling to prevent splashing. Wash thoroughly after use.

**SECTION VIII - PRECAUTIONS FOR SAFE HANDLING AND USE**

Steps to be Taken in Case Material is Released or Spilled

Wear protective equipment to prevent exposure. Stop spill and dike to prevent spreading. Cover spill with absorbent materials and collect into containers. Clean contaminated area with detergent and water or a steam cleaner for best results.

Waste Disposal Method

Dispose in accordance with Federal, State and Local requirements.

Precautions to be Taken in Handling and Storing

Keep containers tightly closed when not in use.

Other Precautions NONE KNOWN.

Prepared by Samet Dy - Urethane Chemist

**PLEASE NOTE** "The above information is accurate to the best of our knowledge. However, since data, safety standards, and government regulations are subject to change and the conditions of handling and use, or misuse, are beyond our control, Dur-A-Flex, Inc. MAKES NO WARRANTY, EITHER EXPRESS OR IMPLIED, WITH RESPECT TO THE COMPLETENESS OR CONTINUING ACCURACY OF THE INFORMATION CONTAINED HEREIN AND DISCLAIMS ALL LIABILITY FOR RELIANCE THEREON. User should satisfy himself that he has all current data relevant to his particular use."



**DUR-A-FLEX**  
INNOVATION FROM THE FLOOR UP

95 Goodwin Street, East Hartford, CT., 06108 (860) 528-9838

# Material Safety Data Sheet

Date Prepared 8/2/2010

<b>SECTION I - IDENTIFICATION</b>	<b>HAZARD RATING</b> 0 = Least 1 = Slight 2 = Moderate 3 = High 4 = Extreme	Health	3
		Flammability	0
		Reactivity	0
		Personal Protection	F
<b>IDENTITY (As Used on Label)</b>	<b>Dur-A-Crete Aggregate</b>		
<b>COMMON NAME</b>	Natural Aggregates Blend		

<b>SECTION II - PRODUCT COMPONENTS</b>	<b>CAS.#</b>	<b>OSHA PEL</b>	<b>ACGIH TLV</b>
Crystalline Silica (Quartz) <sup>1</sup>	14808-60-7	<u>10mg/m<sup>3</sup></u>	0.1 mg/m <sup>3</sup>
		%SiO <sub>2</sub> +2	

<sup>1</sup>Crystalline silica can be a lung injury and cancer hazard. Do not breathe dust. May cause delayed lung injury. Long term exposure can cause silicosis, a respiratory disease which can result in a delayed, disabling, and sometimes fatal lung injury. Crystalline silica inhaled from occupational sources can cause cancer in humans. Risk of injury is dependent on the duration and level of exposure. A single exposure will not result in serious and adverse effects.

T.S.C.A. Status - O.K. on all above components.  
**\*FOR SPILL, LEAK, FIRE, OR ACCIDENT, CALL CHEMTREC 24-HOUR EMERGENCY NUMBER 1-800-424-9300\***

<b>SECTION III - PHYSICAL/CHEMICAL CHARACTERISTICS</b>			
Boiling Point	4,000F	Specific Gravity (H <sub>2</sub> O = 1)	>1
Vapor Pressure (mm Hg)	N/A	Melting Point	3,000F
Vapor Density (AIR = 1)	N/A	Evaporation rate (Butyl Acetate = 1)	N/A
Volatile Organic Compounds (VOC) = Zero grams/liter			
Solubility in Water	Insoluble		
Appearance and Odor	Natural Aggregate. No odor.		

<b>SECTION IV - FIRE and EXPLOSION HAZARD DATA</b>				
Flash Point (Closed Cup Method)	N/A	Flammable Limits	LEL	UEL
			N/A	N/A
Extinguishing Media	N/A			
Special Firefighting Procedures	N/A			
Unusual Fire and Explosion Hazards	N/A			

<b>SECTION V - REACTIVITY DATA</b>			
Stability	Unstable		Conditions to Avoid
	Stable	X	NONE KNOWN
Incompatibility (Materials to Avoid)	Hydrofluoric acid and powerful oxidizing agents.		
Hazardous Decomposition or Byproducts	NONE KNOWN		
Hazardous Polymerization	May Occur		Conditions to Avoid
	Will Not Occur	X	NONE KNOWN

## SECTION VI - HEALTH HAZARD DATA

Route(s) of Entry:	Inhalation?	Skin?	Ingestion?
	Yes	YES	YES

Signs and Symptoms of Exposure Shortness of breath and reduced pulmonary function.

Health Hazards (Acute and Chronic) Note: Persons with lung disorders or who are sensitized should not use this product.

ACUTE - No symptoms

CHRONIC - excessive inhalation of dust may result in respiratory disease such as silicosis, pulmonary fibrosis, etc. The IARC has evaluated in Vol. 42 (monographs) that there is "sufficient evidence for the carcinogenicity of crystalline silica dust to experimental animals" and "limited evidence" with respect to humans.

Carcinogenicity:	NTP?	IARC Monographs?	OSHA Regulated?
	Yes (Respirable Quartz)	Yes * Level 2A Grouping	No

Medical Conditions Generally Aggravated by Exposure  
Lung disorders and persons subject to eye irritation.

### Emergency and First Aid Procedures

EYES - Flush with water, holding lids open for 15 minutes or more. Call physician for advice if necessary.

SKIN - PROMPTLY wash with soap and water. DO NOT wash with solvents. Seek medical advice if irritation develops or persists.

INHALATION - Move person to fresh area if effects occur. If needed, give oxygen or artificial respiration to improve breathing. Consult physician.

INGESTION - Expected to be slightly toxic by ingestion. If swallowed, induce vomiting immediately as directed by a physician.

Get medical attention immediately. Never give liquids to an unconscious or convulsing person.

OTHER HEALTH EFFECTS - Medical conditions which may be aggravated by exposure to this product include, conjunctivitis of the eye, dermatitis of the skin, asthma and respiratory diseases. Sensitization may occur by skin contact.

**\*\*NOTE\*\*** persons with lung disorders or who are sensitized should not use this product.

## SECTION VII - CONTROL MEASURES

Respiratory Protection (Specify Type): Atmospheric levels should be maintained below the exposure limits listed in section II by using engineering controls. Provide adequate exhaust ventilation and/or NIOSH approved cartridge respirator.

Ventilation	Local Exhaust	If needed.	Special	None Known.
	Mechanical	Adequate exhaust ventilation must exhaust AWAY from applicator.		

Protective Gloves	Natural rubber or Neoprene.	Eye Protection	Splash goggles or face shield.
-------------------	-----------------------------	----------------	--------------------------------

### Other Protective Clothing or Equipment

Use adequate ventilation and dust collection. To minimize exposure, wear a respirator approved for silica dust when using, handling, storing or disposing of this product. Refer to the most recent standards of ANSI (Z88.2), OSHA (29 CFR 1910.134), MSHA (30 CFR Parts 56 and 57), and NIOSH Respirator Decision Logic. Maintain, clean and fit test respirators in accordance with OSHA regulations.

Work/Hygienic Practices Avoid creating and breathing dust.

## SECTION VIII - PRECAUTIONS FOR SAFE HANDLING AND USE

### Steps to be Taken in Case Material is Released or Spilled

Do not breathe dust. Do not rely on your sight to determine if dust is in the air. Silica may be in the air without a visible dust cloud. Avoid creation of respirable dust

### Waste Disposal Method:

Dispose in accordance with Federal, State and Local requirements.

Avoid creation of respirable dust. Take precaution against bag breakage

Other Precautions NONE KNOWN.

Prepared By: Samet Dy -Chemist

**PLEASE NOTE** "The above information is accurate to the best of our knowledge. However, since data, safety standards, and government regulations are subject to change and the conditions of handling and use, or misuse, are beyond our control, Dur-A-Flex, Inc. MAKES NO WARRANTY, EITHER EXPRESS OR IMPLIED, WITH RESPECT TO THE COMPLETENESS OR CONTINUING ACCURACY OF THE INFORMATION CONTAINED HEREIN AND DISCLAIMS ALL LIABILITY FOR RELIANCE THEREON. User should satisfy himself that he has all current data relevant to his particular use."



**DUR-A-FLEX**  
INNOVATION FROM THE FLOOR UP

95 Goodwin Street, East Hartford, CT., 06108 (860) 528-9838

# Material Safety Data Sheet

Date Prepared 8/2/2010

## SECTION I - IDENTIFICATION

**IDENTITY (As Used on Label)** Dur-A-Gard Hardener: No Sag, Regular, OPF, Fast, Crete-Gard

**COMMON NAME** Amine Curative for Epoxy resin

HAZARD RATING 0 = Least  1 = Slight 2 = Moderate 3 = High 4 = Extreme	Health	3
	Flammability	1
	Reactivity	0
	Personal Protection	G

SECTION II - PRODUCT COMPONENTS	CAS.#	OSHA PEL	ACGIH TLV
---------------------------------	-------	----------	-----------

SECTION II - PRODUCT COMPONENTS	CAS.#	OSHA PEL	ACGIH TLV
Benzyl Alcohol	100-51-6	N.E. <sup>1</sup>	N.E.
3, Aminomethyl -3,5,5-Trimethyl	2855-13-2	N.E.	N.E.
1, 5 Pentanediamine, 2 Methyl	15520-10-2	N.E.	N.E.
N, Aminoethyl Piperazine	140-31-8	N.E.	N.E.
Diglycidyl Ether Bisphenol A Epoxy Resin	25085-99-8	N.E.	N.E.
Salicylic Acid	69-72-7	N.E.	N.E.
Polyoxypropylenediamine	9046-10-0	N.E.	N.E.
Amorphous Fumed Silica	7631-86-9	N.E.	N.E.
Propylene Glycol Monomethyl Ether	107-98-2	N.E.	N.E.
Nonyl Phenol	84852-15-3	N.E.	N.E.
Triphenyl Phosphite	101-02-0	N.E.	N.E.

<sup>1</sup>None Established

T.S.C.A. Status - O.K. on all above components.

**\*FOR SPILL, LEAK, FIRE, OR ACCIDENT, CALL CHEMTREC 24-HOUR EMERGENCY NUMBER 1-800-424-9300\***

## SECTION III - PHYSICAL/CHEMICAL CHARACTERISTICS

Boiling Point	250°F	Specific Gravity (H2O = 1)	< 1
Vapor Pressure (mm Hg)	12.6	Melting Point	N/A
Vapor Density (AIR = 1)	N/A	Evaporation rate (Butyl Acetate = 1)	0.7
Solubility in Water	Partially soluble.		
Appearance and Odor	Clear low viscosity liquid. Mild amine odor.		

## SECTION IV - FIRE and EXPLOSION HAZARD DATA

Flash Point (Closed Cup Method)	100°F	Flammable Limits	LEL	UEL
			N/A	N/A

Extinguishing Media Water spray, Foam, CO<sub>2</sub>, Dry Chemicals.

Special Firefighting Procedures

Wear full protective equipment including self-contained breathing apparatus.

Irritating and/or toxic gases may be generated by fire.

Unusual Fire and Explosion Hazards

Cool storage containers with water spray to prevent pressure build-up that may rupture the containers.

## SECTION V - REACTIVITY DATA

Stability	Unstable		Conditions to Avoid
	Stable	X	Keep containers closed when not in use.
Incompatibility (Materials to Avoid)	Strong oxidizers and acids.		
Hazardous Decomposition or Byproducts	By Fire - Carbon monoxide, Carbon dioxide, Nitrogen oxides.		
Hazardous Polymerization	May Occur		Conditions to Avoid
	Will Not Occur	X	Uncontrolled reaction with epoxy resins.

## SECTION VI - HEALTH HAZARD DATA

Route(s) of Entry:	Inhalation?	Skin?	Ingestion?
	YES	YES	YES

Signs and Symptoms of Exposure Irritation of skin.

Health Hazards (Acute and Chronic)

ACUTE - Irritation of skin and dermatitis.

CHRONIC - Repeated overexposure will cause severe skin irritation, dermatitis and sensitization. Sensitized persons may experience rapid irritation of skin upon exposure.

Persons with lung disorders or who are sensitized should not use this product.

Carcinogenicity:	NTP?	IARC Monographs?	OSHA Regulated?
	NO	NO	NO

Medical Conditions Generally Aggravated by Exposure  
Allergy, skin disorders.

Emergency and First Aid Procedures

EYES - Flush with water, holding lids open for 15 minutes or more. Call physician for advice if necessary.

SKIN - PROMPTLY wash with soap and water. DO NOT wash with solvents. Seek medical advice if irritation develops or persists.

INHALATION - Move person to fresh air if effects occur. If needed, give oxygen or artificial respiration to improve breathing. Consult physician.

INGESTION - Get medical attention immediately. Never give liquids to an unconscious or convulsing person.

## SECTION VII - CONTROL MEASURES

Respiratory Protection (Specify Type)

Provide adequate exhaust ventilation; use a NIOSH approved respirator if PELS/TLVS are exceeded.

Ventilation	Local Exhaust	If needed.	Special	None known.
	Mechanical	Adequate exhaust ventilation must exhaust AWAY from applicator.		

Protective Gloves	Natural rubber or Neoprene.	Eye Protection	Splash goggles or face shield.
-------------------	-----------------------------	----------------	--------------------------------

Other Protective Clothing or Equipment

Use rubber apron, face shield and appropriate clothing to prevent contact with skin. Launder contaminated clothing before reuse. Discard contaminated leather shoes and canvas sneakers. Protective skin creams help cleaning with soap and water, gloves must still be worn. An eye wash station or an adequate supply of clean water must be available at work area.

Work/Hygienic Practices Enforce careful handling to prevent splashing. Wash thoroughly after use.

## SECTION VIII - PRECAUTIONS FOR SAFE HANDLING AND USE

Steps to be Taken in Case Material is Released or Spilled

Wear protective equipment to prevent exposure. Stop spill and dike to prevent spreading. Cover spill with absorbent materials and collect into containers. Clean contaminated area with detergent and water or a steam cleaner for best results.

Waste Disposal Method

Dispose in accordance with Federal, State and Local requirements.

Precautions to be Taken in Handling and Storing

Keep containers tightly closed when not in use.

Other Precautions NONE KNOWN.

Prepared by Samet Dy - Chemist

**PLEASE** "The above information is accurate to the best of our knowledge. However, since data, safety standards, and government regulations are subject to change and the conditions of handling and use, or misuse, are beyond our control, Dur-A-Flex, Inc. MAKES NO WARRANTY, EITHER EXPRESS OR IMPLIED, WITH RESPECT TO THE COMPLETENESS OR CONTINUING ACCURACY OF THE INFORMATION CONTAINED HEREIN AND DISCLAIMS ALL LIABILITY FOR RELIANCE THEREON. User should satisfy himself that he has all current data relevant to his particular use."

**NOTE**



95 Goodwin Street, East Hartford, CT., 06108 (860) 528-9838

# Material Safety Data Sheet

Date Prepared 9/1/2008

<b>SECTION I - IDENTIFICATION</b>	HAZARD RATING 0 = Least 1 = Slight 2 = Moderate 3 = High 4 = Extreme	Health	1
		Flammability	1
		Reactivity	0
		Personal Protection	G
IDENTITY (As Used on Label) <b>Dur-A-Gard Resin: all colors/Bio-Pruf®</b>			
COMMON NAME <b>Pigmented Epoxy Resin</b>			

SECTION II - PRODUCT COMPONENTS	CAS.#	OSHA PEL	ACGIH TLV
Diglycidyl Ether Bisphenol A Epoxy Resin	25068-38-6	N.E. <sup>1</sup>	N.E.
Aliphatic Glycidyl Ether Diluent	68609-97-2	N.E.	N.E.
Titanium Dioxide	13463-67-7	15mg/m <sup>3</sup>	10mg/m <sup>3</sup>
Calcium Carbonate	1317-65-3	15mg/m <sup>3</sup>	10mg/m <sup>3</sup>
Aluminum Silicate	1332-58-7	15mg/m <sup>3</sup>	2mg/m <sup>3</sup>
Barium Sulfate <sup>2</sup>	7727-43-7	10mg/m <sup>3</sup>	10mg/m <sup>3</sup>
Inorganic Iron Oxides	1309-37-1	15mg/m <sup>3</sup>	10mg/m <sup>3</sup>
Chromium(III) Oxide Green(trivalent chromium) <sup>*3</sup>	1308-38-9	1mg/m <sup>3</sup>	0.5mg/m <sup>3</sup>

<sup>1</sup>Not Established

<sup>2</sup>Barium Sulfate is listed in SARA III, Part 372, Section 313.

<sup>\*3</sup>This product contains only 1-3ppm (0.0001%-0.0003%) leachable hexavalent chromium. Trivalent chromium is not specifically listed as a possible carcinogen. Only in Dark Green and Light Green pigmented systems.

T.S.C.A. Status - O.K. on all above components.

**\*FOR SPILL, LEAK, FIRE, OR ACCIDENT, CALL CHEMTREC 24-HOUR EMERGENCY NUMBER 1-800-424-9300\***

## SECTION III - PHYSICAL/CHEMICAL CHARACTERISTICS

Boiling Point	N/A	Specific Gravity (H2O = 1)	1.55
Vapor Pressure (mm Hg)	N/A	Melting Point	N/A
Vapor Density (AIR = 1)	N/A	Evaporation rate (Butyl Acetate = 1)	N/A
Volatile Organic Compounds (VOC)	0 g/L		
Solubility in Water	NONE		
Appearance and Odor	Pigmented viscous liquid. Mild characteristic odor.		

## SECTION IV - FIRE and EXPLOSION HAZARD DATA

Flash Point (Closed Cup Method)	485°F	Flammable Limits	LEL	UEL
			N/A	N/A

Extinguishing Media Water spray, Foam, CO<sub>2</sub>, Dry Chemicals.

Special Firefighting Procedures

Wear full protective equipment including self-contained breathing apparatus.

Unusual Fire and Explosion Hazards

Cool storage containers with water spray to prevent pressure build-up that may rupture the containers.

Combustion products may be toxic.

## SECTION V - REACTIVITY DATA

Stability	Unstable		Conditions to Avoid
	Stable	X	Excess heating over long periods of time degrades the resin.

Incompatibility (Materials to Avoid) Uncontrolled reaction with amines.

Hazardous Decomposition or Byproducts By Fire - Carbon monoxide, Carbon dioxide, Nitrogen oxides, Aldehydes.

Hazardous Polymerization	May Occur		Conditions to Avoid
	Will Not Occur	X	Uncontrolled reaction with amines.

**SECTION VI - HEALTH HAZARD DATA**

Route(s) of Entry:	Inhalation?	Skin?	Ingestion?
	YES	YES	YES
Signs and Symptoms of Exposure	Irritation of skin.		
Health Hazards (Acute and Chronic)			
ACUTE - Irritation of skin and dermatitis.			
CHRONIC - Repeated overexposure will cause severe skin irritation, dermatitis and sensitization. Sensitized persons may experience rapid irritation of skin upon exposure.			
Persons with lung disorders or who are sensitized should not use this product.			
Carcinogenicity:	NTP?	IARC Monographs?	OSHA Regulated?
	NO	NO	NO

Medical Conditions Generally Aggravated by Exposure  
 Allergy, skin disorders.

Emergency and First Aid Procedures

EYES - Flush with water, holding lids open for 15 minutes or more. Call physician for advice if necessary.

SKIN - PROMPTLY wash with soap and water. DO NOT wash with solvents. Seek medical advice if irritation develops or persists.

INHALATION - Move person to fresh air if effects occur. If needed, give oxygen or artificial respiration to improve breathing. Consult physician.

INGESTION - Get medical attention immediately. Never give liquids to an unconscious or convulsing person.

**SECTION VII - CONTROL MEASURES**

Respiratory Protection (Specify Type)

Provide adequate exhaust ventilation; use a NIOSH approved respirator if PELS/TLVS are exceeded.

Ventilation	Local Exhaust	If needed.	Special	None known.
	Mechanical	Adequate exhaust ventilation must exhaust AWAY from applicator.		

Protective Gloves      Natural rubber or Neoprene.      Eye Protection      Splash goggles or face shield.

Other Protective Clothing or Equipment

Use rubber apron, face shield and appropriate clothing to prevent contact with skin. Launder contaminated clothing before reuse. Discard contaminated leather shoes and canvas sneakers. Protective skin creams help cleaning with soap and water, gloves must still be worn. An eye wash station or an adequate supply of clean water must be available at work area.

Work/Hygienic Practices      Enforce careful handling to prevent splashing. Wash thoroughly after use.

**SECTION VIII - PRECAUTIONS FOR SAFE HANDLING AND USE**

Steps to be Taken in Case Material is Released or Spilled

Wear protective equipment to prevent exposure. Stop spill and dike to prevent spreading. Cover spill with absorbent materials and collect into containers. Clean contaminated area with detergent and water or a steam cleaner for best results.

Waste Disposal Method

Dispose in accordance with Federal, State and Local requirements.

Precautions to be Taken in Handling and Storing

Keep containers tightly closed when not in use.

Other Precautions      NONE KNOWN.

Prepared by      Samet Dy - Chemist

**PLEASE NOTE** "The above information is accurate to the best of our knowledge. However, since data, safety standards, and government regulations are subject to change and the conditions of handling and use, or misuse, are beyond our control, Dur-A-Flex, Inc. MAKES NO WARRANTY, EITHER EXPRESS OR IMPLIED, WITH RESPECT TO THE COMPLETENESS OR CONTINUING ACCURACY OF THE INFORMATION CONTAINED HEREIN AND DISCLAIMS ALL LIABILITY FOR RELIANCE THEREON. User should satisfy himself that he has all current data relevant to his particular use."



These colors apply to Epoxy, Methyl Methacrylate (MMA), Thin Mil Urethane topcoats and Add-A-Color field mixed pigments.



**WHITE\*\***

DUR-A-FLEX

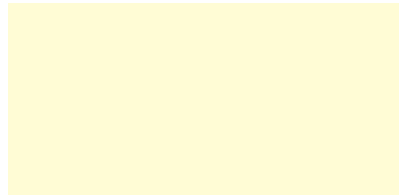

**IVORY\***

DUR-A-FLEX



**BEIGE**

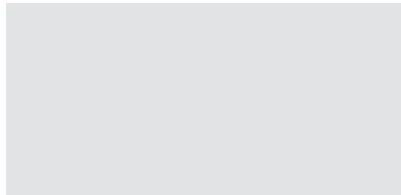

**LIGHT GREY**



**MEDIUM GREY**



**SLATE GREY**

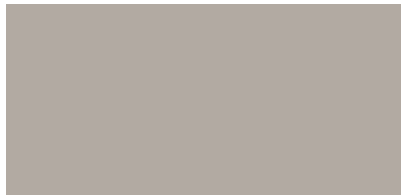

**CONCRETE GREY**

DUR-A-FLEX



**CHARCOAL**

DUR-A-FLEX



**SMOKE BLUE\***

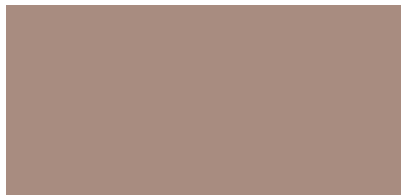

**CARAMEL\***

DUR-A-FLEX



**SAFETY RED\***

DUR-A-FLEX



**TILE RED**



**BRIGHT YELLOW**



**GREEN**



**BLACK**

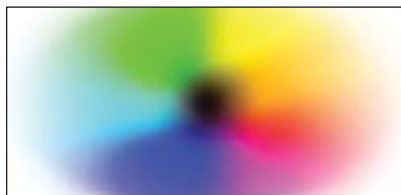

**CUSTOM COLORS AVAILABLE**

Colors may be affected by age, heat and exposure to sunlight. Please request an actual color sample of the product that you are considering to confirm the most accurate representation.

Due to chemical composition, thickness, application methods and job site conditions, there may be slight variations of individual colors across various product lines.

\*Not available in MMA

\*\*Not available in Shop Floor



DUR-A-FLEX, INC. has developed this document to help Facility Owners, Architects, Engineers, Specification Writers, and Contractors gain a better understanding of the importance of a properly prepared substrate, and the methods to achieve an appropriate bond. This document is intended to be a general guideline, for specific jobsite information, please contact your local DUR-A-FLEX Representative.

There are many satisfactory methods of preparing a substrate to receive a DUR-A-FLEX flooring system. The preparation method is typically chosen based on service requirements, time allowed for entire process and accessibility.

### **PERSONAL PROTECTION EQUIPMENT**

It is the responsibility of the surface preparation contractor and the flooring contractor to insure that all personnel are properly protected from hazards. DUR-A-FLEX is committed to promoting awareness regarding these potential hazards. All DUR-A-FLEX products are rated according to the Hazardous Material Identification System (HMIS). OSHA regulations specify when, where and how workers are to be protected. These regulations and the local OSHA officials should be consulted as necessary to insure proper protection, compliance with the law, and to avoid liability issues. Safety and health issues should be addressed prior to the start the job.

### **TESTING**

#### **MOISTURE CONCERNS**

Please refer to the [Floor Evaluation Flow Chart](#) in the Contractor's Center of our website for a step-by-step process to determine the condition of the concrete.

#### **Testing For An Existing Sealer**

Test to see if the floor is "sealed" by pouring a small amount of muriatic acid on the floor in several spots. If it "froths" instantly, the floor is not sealed. If the acid doesn't froth immediately, a sealer and/or paint is present and must be removed by scarifying, steel shot blasting or other mechanical methods.

#### **Salt Contamination Testing**

Salt contaminated slabs that contain steel reinforcement are very susceptible to corrosion of the reinforcing steel. As the steel corrodes it expands causing cracking, delamination of

concrete and any toppings bonded to it, and eventually, structural failure of the slab. Obvious signs of chloride or salt contamination are spalled concrete with exposed, rusted reinforcing steel. Testing is recommended to determine the depth of contamination and the extent of corrosion activity. A Litmus Test for pH will determine the presence of chloride or acid contamination, if the pH is below 10.

#### **Bond Test**

The purpose of the bond test is to make sure preparation method is adequate for the primer to bond to the substrate. The test is done only when applying MMA systems. For more information on bond test refer to CRYL-A-PRIME data sheet on our website @ [www.dur-a-flex.com](http://www.dur-a-flex.com).

### **REMOVAL AND REPAIR**

#### **ASTM D 4258-83 Standard practice for surface cleaning concrete for coating.**

This practice includes surface cleaning of concrete to remove grease, dirt, and loose material prior to the application of coatings. Procedures include vacuum cleaning, air blast cleaning, water cleaning, detergent water cleaning, and steam cleaning.

#### **Removal of bond inhibiting contaminants**

This includes, but is not limited to removal of oils, grease, wax, sealers, curing compounds, laitance, salts and any other hydrocarbon based materials. This will ensure that a good bond takes place between the resinous flooring and the concrete substrate.

#### **Removal of Adhesives, Mastics and Membranes**

In many retrofit projects, existing tile, VCT or sheet goods are being replaced with polymer flooring systems. Removal of the floor finish will often leave a layer of some type of mastic, adhesive or membrane. In thin applications these materials can often be totally cleaned up by

shotblasting the concrete. In thicker applications, the steel shot will tend to bounce, requiring additional preparation with the use of scarifying equipment or possibly even the use of chemical strippers. Wherever possible, consult the DUR-A-FLEX Tech Service Department or your local DUR-A-FLEX Flooring Contractor and schedule a site visit to investigate the best removal methods.

**Removal of Existing Seamless Floor**

Like mastics and adhesives, the need to remove an existing seamless floor will occasionally arise. There has been much progress made in the development of equipment for removal of resurfacers. Typically, removal requires a heavy grinder with “rotating heads”. These heads can be outfitted with different “teeth” or carbide “blades” for removal of a particular type of overlay.

**REASONS FOR SURFACE PREPARATION**

Surface preparation of a concrete substrate is required to remove surface laitance to create a surface profile and porosity for adhesion of polymer floor systems.

**METHODS OF SURFACE PREPARATION**

Care should be taken to define the degree of abrasion required for the coating system so that the concrete will not be eroded beyond what is necessary. All concrete surfaces should be abraded to remove laitance and contaminants. The following Table describes the required profiles according to the ICRI guidelines for various coating systems.

Coating	Coating Thickness	Concrete Surface Profile (CSP)
Sealers	3 mil	CSP 2-3
High-Build	10-40 mil	CSP 3-4
Self-Leveling	50 mils-1/8”	CSP 4-5
Polymer Overlay	1/8-1/4”	CSP 5-7

**Shotblasting**

Shotblasting is the recommended method of surface preparation of concrete for most polymer floor installations. Shotblast equipment utilizes an alloy wheel spinning at high speeds to throw small steel particles at the substrate in a controlled, dry, 99% dust-free operation. This process removes surface contamination, adds profile and vacuums the concrete clean in one

process. The size and angularity of shot, along with the travel speed of the unit, can be adjusted to determine the degree of the surface profile. Because shotblasting is a dry preparation process, it allows the installation to begin immediately after completion of prep (surface must be dry before blasting). Shotblasting will also identify weak areas in the surface of the concrete. **NOTE:** When selecting shotblast preparation for thin film coating systems (under 20 mils) be aware that a blast pattern or track lines may be visible.

**Diamond Grinding**

Diamond grinding should only be used in areas inaccessible to shotblasting and then only with coarse diamond wheel.

**Scarifying**

Scarifying is primarily used for the removal of deteriorated concrete, coatings and polymer flooring systems.

**Hand Tool**

Hand tool preparation consists of the use of mechanical tools and equipment designed to abrade or chip away the surface of the concrete. Common tools available include chipping hammers, hand held diamond grinders and concrete crack chasing saws. These tools are typically used to make keyways, prepare edges against walls and columns.

**TYPES OF SUBSTRATES**

**Regular Concrete**

Regular concrete surface must be prepared with a steel shot-blast machine, scarifier, diamond grinder. Floors with oil, grime and grease should first be cleaned with Simoniz 969 Cleaner/Degreaser before preparing. Allow floor to dry. Good ventilation, fans and/or auxiliary heat will accelerate drying time. Do not use oil fired portable heaters.

**Replacement of Structurally Deteriorated Concrete**

Replacement of structurally deteriorated concrete must be done in accordance with The International Concrete Repair Institute (ICRI) Bulletin. Patching material must be a DUR-A-FLEX approved patching material. Make sure of minimum cure time before installation of resinous flooring. DUR-A-FLEX flooring Contractors should be contracted whenever possible to complete these repairs appropriately.

### **Fiber Filled Concrete**

Fiber filled concrete must be burned with a propane weed burner, swept and vacuumed perfectly clean and then primed. When primer has completely cured, the floor must be sanded and tack ragged (This step may not be necessary for thick resurfacing systems).

### **Quarry/Ceramic Tile**

Quarry/Ceramic tile have been successfully resurfaced on many projects without removal of tile and setting bed. A site investigation along with cores through the entire slab will help identify the type of setting bed, the existence of any waterproofing membranes, additional toppings, or other unusual existing conditions. Water trapped within the floor will create long-term sanitation and performance problems.

If the tile is well bonded and placed over an unsaturated latex setting bed, the floor may be resurfaced as follows: Surface must be mechanically abraded with a steel shot-blast machine, scarifier or diamond grinder and vacuumed perfectly clean. "Tack rag" area to remove dust and to soften surface. Apply DUR-A-FLEX recommended Poly-Crete or Hybri-Flex systems or DUR-A-GLAZE TIECOAT or CRYL-A-PRIME P-101 with CRYL-A-BOND MT primer to the entire area immediately and allowed to cure.

### **Existing Epoxy Coating/Resurfacer**

Existing seamless floors may be resealed or resurfaced from time to time due to excessive wear or the need to change the appearance or skid-resistance of the floor. The existing floor should first be cleaned and degreased with EZ-CLEAN floor cleaner/degreaser. It must then be mechanically abraded with a floor-sanding machine or a steel shot blast machine to totally remove gloss. Vacuum perfectly clean. "Tack rag" area to remove dust and to soften surface. Apply DUR-A-GLAZE TIE-COAT to entire area immediately followed by subsequent epoxy coatings.

### **Plywood**

The plywood substrate must be sound and non-flexing under the expected load. Typical plywood substrate must be exterior or marine grade, new, clean, and smooth finish (NO KNOTS.). Two layers with staggered joints are required. Plywood should be positively fastened to the existing surface with a high quality construction adhesive as well as a 6" screw pattern.

For further information on plywood substrates, please contact your local sales representative or DUR-A-FLEX technical department.

### **Walls**

#### **For Dur-A-Wall Applications:**

Block wall: Apply Dulux (ICI) block filler to fill pores over new or existing concrete block following manufacturer's instructions.

Drywall: Drywall must be finished to a level #4 or #5 finish prior to coating. Prime with ICI GRIPPER Multipurpose primer or GLIDDEN GRIPPER primer. Substrate will affect final appearance of wall coating.

Cast in place Concrete and Ceramic Tile:  
Use DUR-A-GLAZE 4 RESIN COVE-REZ thickened with Cab-O-Sil, M5, or No-Sag #2 (1.5 times the resin volume) with DUR-A-GLAZE 4 FAST Hardener to fill pores and cracks.

**Multiple applications of filler material maybe necessary. Sand or grind between coats to achieve a smooth surface.**

**NOTE: Tile and block grout lines may "mirror through" the finished system even though the surface is smooth.**

### **CRACKS AND JOINTS**

Refer to Joint Guidelines for complete details on our website in the Contractor Center section @ [www.dur-a-flex.com](http://www.dur-a-flex.com).

1/2010SURFACEPREP

***Before using any DUR-A-FLEX, Inc. Product, be sure the Material Safety Data Sheet is read and understood.***

Flooring problems on concrete from vapor emission, dew point, alkalinity; pH, etc. cause millions of dollars in repair and replacement costs annually. By recognizing potential problems, testing for and mitigating them, steps can be taken to ensure a long lasting, successful flooring installation.

### **What is the traditional failure mode because of “moisture” problems?**

There are two ways a polymeric floor can fail: (1) the floor system was never able to bond properly at the time of installation or (2) there were factors present at the time of installation to cause the bond to fail. Symptoms of failure on an already installed floor may include bubbles, blisters and/or delamination.

### **What causes a polymeric floor to fail?**

Traditional theory has focused primarily on moisture failure such as capillary and hydrostatic, however more recent research has found that although moisture plays a role, it is not the only factor. In reality, the presence of ionic compounds in the concrete plays an even more significant role. For this reason we strongly recommend that you **do not rely on moisture testing alone to avoid floor failure!**

Through the chemical analysis of several thousand concrete cores we have developed a patent-pending process that can actually predict future moisture blister generation on concrete.

During the evaluation of these cores, we learned some slabs with moisture vapor emission rates of 25 lbs./1000 s.f./24 hours by calcium chloride as well as 95+% RH did not blister. Conversely, we saw slabs with much lower emission rates blister severely. We also understand that many slab owners are paying to install “moisture mitigation systems” to insure the flooring installed on top won’t blister; yet in some cases, **blisters still occur!**

We also learned that specific ionic components of the surface chemistry of the slab (top 0-3/16”(5mm)), when present at certain levels, would predict moisture blisters **100% of the time.** Without this combination of compounds, regardless of the moisture levels, blisters wouldn’t occur.

### **What is the main factor that will cause a failure?**

Osmosis is one of the main factors that can cause floor failure. Osmosis occurs when actual moisture vapor emission through the concrete slab is seeking to equalize the soluble ions at the surface of the concrete slab. This creates a pressure that can be greater than the adhesion strength of the coating. Four conditions are needed for osmosis to occur: (1) a semi-permeable membrane, which

can be the polymer primer or the upper layers of the slab, (2) a gradient of ionic activity (soluble salts), (3) a source of moisture vapor and (4) An impermeable prime, base and/or topcoat. If any one of these is removed, osmotic blistering cannot occur. And we aren’t talking all theory here. We can make blisters happen on command!

### **What is Moisture Vapor Emission?**

Water is added to turn cement, sand and aggregate into a concrete slab. There is a critical volume of water needed to “hydrate” the concrete, and an excess volume of water used to make the concrete pour-able and workable. Moisture Vapor Emission is movement of moisture that is not part of the concrete mix. It could be from ground water, plumbing, or landscaping runoff, etc. This moisture is a concern when the concrete slab has no vapor retarder installed, or the vapor retarder has been punctured.

### **How were moisture failures predicted?**

Up until recently, there were three methods recommended to pre-test for moisture related floor failures; the plastic sheet method, Calcium Chloride using ASTM F1869, and Relative Humidity using ASTM F2170.

### **How will moisture failures be predicted by Dur-a-Flex?**

Dur-A-Flex has developed a flow chart to assist you in determining what floor system will work best based on the test results of core samples and, where appropriate, relative humidity testing. (See flow chart on following page) If you are planning to use our Epoxy or MMA, use in-situ Relative Humidity Testing per ASTM F-2170-02 as a quantitative test method.

Unlike traditional calcium chloride testing, RH as well as core test results are not significantly impacted by ambient temperature and relative humidity conditions in the building.

### **What determines my flooring options?**

Depending on the level of ionic compounds in your core samples, your floor will fall into one of four levels. Your test report will specify this level allowing you to select the best floor option as shown on the flow chart.

# Floor Evaluation Flow Chart

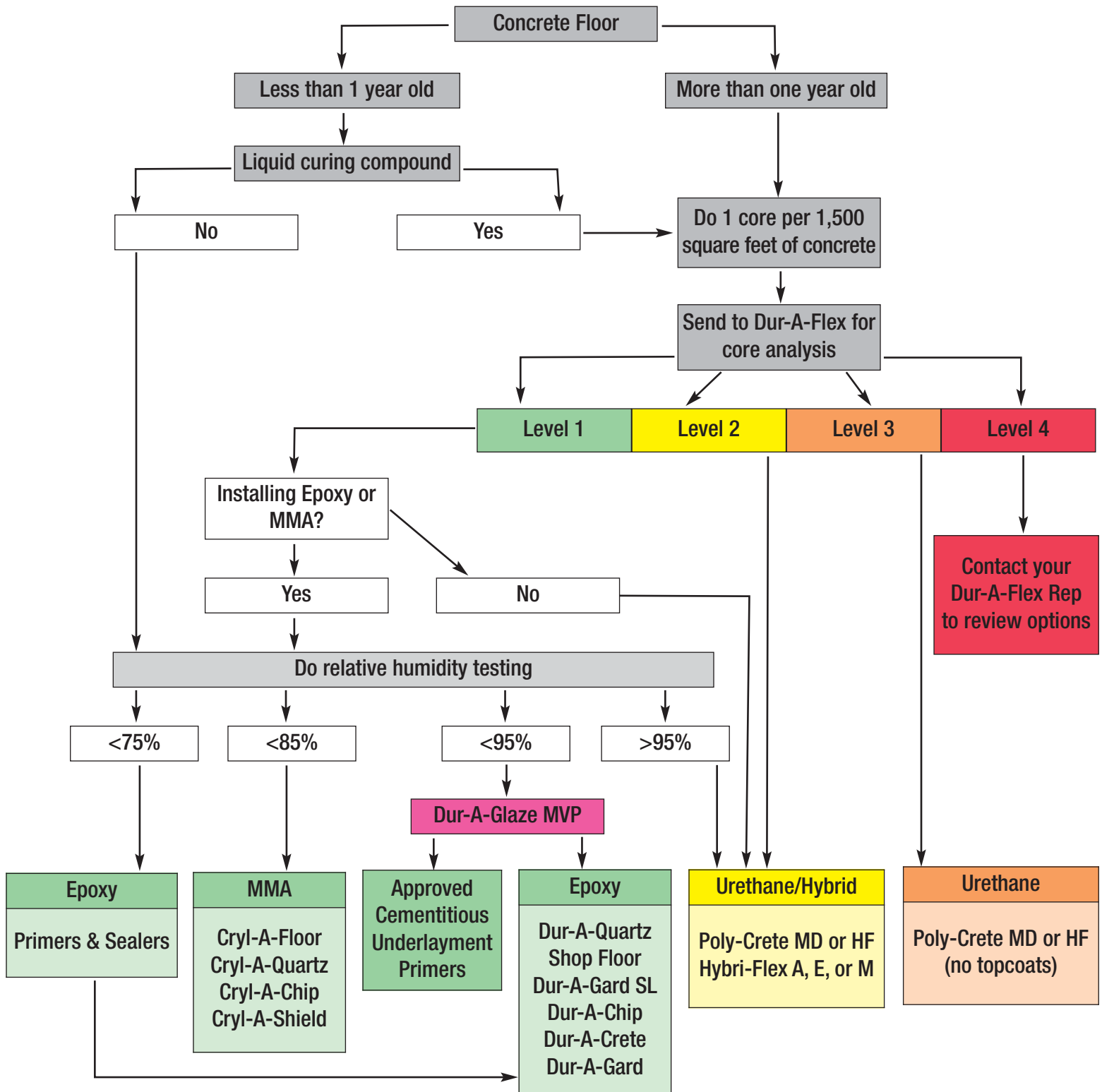

## Dur-A-Flex Chemical Resistance Data

R = Recommended (no change)

S = Splash &amp; spill (slight change)

N = Not recommended (attack)

 \***Bold**\* = Stains

Chemical Name	% Conc.	Epoxies					Urethanes							Acrylics
		Dur-A-Gard	Glaze #4	Nov - olac	Ultra Clear	Armor Top	Glaze #5	Poly-Thane 1	Poly-Thane 2 HS	Poly-Crete HF MD TF	Poly-Crete CF	Poly-Crete KT	MMA	
Acetic Acid	10%	R	R	R	R	R		R	R	R	R	R	R	R
Acetic Acid	30%	S	S	S	R	R		S	R	S	R		R	S
Acetic Acid	50%	N	N	N	R	N		S	R	S	S		S	N
Acetic Acid,3%, and Propionic Acid		R	R	R	R				R	R	R		R	R
Acetone		N	N	N	N		R	S	R	R		R		N
Acid Clean		S	S	S	R				S	S				
ACP-99 Ketone		N	N	N	S				R	R				N
Alum	48%	N	N	N	R				S	S	S		S	R
<b>*Aminoethanolamine*</b>		<b>*R*</b>	<b>*R*</b>	<b>*R*</b>	<b>*R*</b>				<b>*R*</b>	<b>*R*</b>	R		R	<b>*R*</b>
Ammonia	30%	R	R	R	R	R	R		R	R	R	R	R	R
Ammonium Hydroxide	30%	R	R	R	R		R	R	R	R	R	R	R	S
Antifreeze		R	R	R	R	R	R	R	R	R	R	R	R	R
Aromatic 100		S	S	S	R				R	R	S		S	
Aromatic hydrocarbons-Super Hiflash 100		S	S	S	R				R	R	S		S	
Benzene		N	N	N	S				R	R	N		N	N
Benzyl Alcohol	Photo	S	S	S	R				R	R	S	S	S	N
<b>Betadine</b>			<b>*S*</b>			<b>*S*</b>	<b>*R*</b>	<b>*S*</b>	<b>*R*</b>	<b>*R*</b>				<b>*R*</b>
Boric Acid	4%	R	R	R	R				R	R	R		R	R
Brake Fluid, DOT 3		S	S	S	S	S	R		R	R	S		S	R
Butanol/Methyl Cellosolve		N	N	N	S				R	R	N		N	N
Butyl Alcohol		S	S	S	R				R	R	S		S	N
Butyl Carbitol		S	S	S	R				R	R				N
Butyl Cellosolve		N	N	N	S				R	R				N
Butyl Cellosolve acetate		N	N	N	S				R	R				N
Carbon Tetrachloride		R	R	R	R				R	R				N
Caustic Soda solution		R	R	R	R				R	R	R	R	R	R
<b>*Chromic Acid*</b>	10%	<b>*R*</b>	<b>*R*</b>	<b>*R*</b>	<b>*R*</b>	<b>*S*</b>	<b>*R*</b>	<b>*S*</b>	<b>*R*</b>	<b>*R*</b>	<b>*R*</b>	<b>*R*</b>	<b>*R*</b>	<b>*R*</b>
<b>*Chromic Acid*</b>	40%	<b>*N*</b>	<b>*N*</b>	<b>*N*</b>	<b>*R*</b>			<b>*S*</b>	<b>*S*</b>	<b>*S*</b>	<b>*S*</b>	<b>*S*</b>	<b>*S*</b>	<b>*S*</b>
<b>CIP 200 Cleaner</b>		<b>*N*</b>							R					
Citric Acid	10%	R	R	R	R		R	R	R	R	R	R	R	R
Citric Acid	20%	R	R	R	R				R	R	R	R	R	R
Citric Acid	50%	N	N	N	R			S	R	R	R		R	R
Clorox		R	R	R	R		R	S	R	R	R	R	R	R
Coffee						<b>*S*</b>	<b>*R*</b>							
<b>*Cola*</b>	90C	<b>*N*</b>	<b>*N*</b>	<b>*N*</b>	<b>*N*</b>			<b>*R*</b>	<b>*R*</b>	<b>*R*</b>				<b>*R*</b>
Cola	RT	S	S	S	R	S	R	R	R	R	R		R	R
<b>*Copper Sulfate*</b>		<b>*R*</b>	<b>*R*</b>	<b>*R*</b>	<b>*R*</b>				<b>*R*</b>	<b>*R*</b>	<b>*R*</b>		<b>*R*</b>	<b>*R*</b>
<b>*Cupric Chloride*</b>		<b>*R*</b>	<b>*R*</b>	<b>*R*</b>	<b>*R*</b>				<b>*R*</b>	<b>*R*</b>	<b>*R*</b>		<b>*R*</b>	<b>*R*</b>
Cyclohexanone		S	S	S	R				R	R	S		S	R
Detergent, heavy duty		R	R	R	R	R	R		R	R	R	R	R	R
Diacetone alcohol		N	N	N	S				R	R				N
<b>*Dimethyl ethanol amine*</b>		<b>*R*</b>	<b>*R*</b>	<b>*R*</b>	<b>*R*</b>				<b>*R*</b>	<b>*R*</b>				
<b>*Dimethylamineborane*</b>		<b>*R*</b>	<b>*R*</b>	<b>*R*</b>	<b>*R*</b>				<b>*R*</b>	<b>*R*</b>				
DMF		N	N	N	N				R	R	N		N	
Docosanic Acid (in ethanol)	2.50%	N	N	N	R				R	R	N		N	
Drano- (sodium hydroxide and aluminum)		S	S	S	R	S	R		R	R	R	R	R	
<b>DuraPrep</b>			<b>*S*</b>			<b>*S*</b>	<b>*S*</b>	<b>*S*</b>	<b>*R*</b>	<b>*S*</b>				<b>*S*</b>
<b>Eco-lab AC-3 Cleaner</b>		<b>*N*</b>				<b>N</b>	<b>*S*</b>			<b>*S*</b>		<b>N</b>		
Eco-Lab Wash & Walk		R			R		R				R	R	R	
EEP solvent		N	N	N	S	N	R		R	R	N	S	N	N
Ethanol	95%	N	N	N	S		R	S	R	R	S		S	S
Ethyl Acetate	99%	N	N	N	S				R	R	S	S	S	S
Excellerate Cleaner						R	R					R		
Fluoboric Acid		S	S	S	R				R	R				
<b>*Formaldehyde*</b>	37%	<b>*S*</b>	<b>*S*</b>	<b>*S*</b>	<b>*R*</b>		<b>*R*</b>	<b>*R*</b>	<b>*R*</b>	<b>*R*</b>	<b>*R*</b>	<b>*R*</b>	<b>*R*</b>	<b>*R*</b>
Gasoline		R	R	R	R		R		R	R		R		R
Glycol Ether		N	N	N	S				R	R		R		R
Heating Oil-Home		R	R	R	R			R	R	R	R		R	R
Hexane		N	N	N	S				R	R	R		R	R
Hydraulic fluids		R	R	R	R			R	R	R	R	R	R	R
<b>*Hydrochloric Acid*</b>	20%	<b>*R*</b>	<b>*R*</b>	<b>*R*</b>	<b>*R*</b>			<b>*R*</b>	<b>*R*</b>	<b>*R*</b>	<b>*R*</b>	<b>*R*</b>	<b>*R*</b>	<b>*R*</b>
<b>*Hydrochloric Acid*</b>	37%	<b>*R*</b>	<b>*R*</b>	<b>*R*</b>	<b>*R*</b>		<b>*R*</b>	<b>*S*</b>	<b>*R*</b>	<b>*R*</b>	<b>*R*</b>		<b>*R*</b>	<b>*R*</b>
<b>*Hydrofluoric Acid*</b>	40%	<b>*N*</b>	<b>*N*</b>	<b>*N*</b>	<b>*S*</b>				<b>*R*</b>	<b>*S*</b>		<b>*R*</b>		<b>*R*</b>
Hydrofluosilic Acid	30%	R	R	R	R				R	R				R
Hydrogen Peroxide	30%	S	S	S	R		R	S	R	R	R	R	R	R
Hydrogen Peroxide	50%	N	N	N	R	S	S	N	R	R	R	R	R	R
<b>*Iodine Tincture*</b>	2%	<b>*R*</b>	<b>*R*</b>	<b>*R*</b>	<b>*R*</b>		<b>*R*</b>		<b>*R*</b>	<b>*R*</b>	<b>*R*</b>		<b>*R*</b>	<b>*R*</b>
Isopropanol		S	S	S	R		R	R	R	R	S		S	S
Isopropyl Acetate	99%	S	S	S	R				R	R	S		S	N
Jet Fuel		R	R	R	R		R	R	R	R	R		R	R
Lactic Acid	88%	N	N	N	R	N	N	S	S	N	R	S	R	R
Magnesium Hydroxide		R	R	R	R				R	R	R		R	R
MEK		N	N	N	N			S	S	S	N	S	N	N
Methacrylate Monomer		S	S	S	S			N	S	S	N	N	N	N

# Dur-A-Flex Chemical Resistance Data

R = Recommended (no change)

S = Splash & spill (slight change)

N = Not recommended (attack)

\*Bold\* = Stains

Chemical Name	% Conc.	Epoxies					Urethanes							Acrylics
		Dur-A-Gard	Glaze #4	KF	Nov - olac	Ultra Clear	Armor Top	Glaze #5	Poly-Thane 1	Poly-Thane 2	Poly-Crete HF MD TF	Poly-Crete CF	Poly-Crete KT	MMA
Methanol		N	N	N	N			R	R	N	S	N	N	
Methyl Cellosolve		N	N	N	N			R	R		S		N	
Methyl dipropasol solvent		N	N	N	R			R	R		S		N	
Methylene chloride		N	N	N	N			S	N	N	S	N	N	
MIBK		N	N	N	S		R	R	R	N		N	N	
Mineral Oil		R	R	R	R		R	R	R	R		R	R	
Mineral Spirits		S	S	S	R		R	R	R		R		R	
Mixed Chlorinated Waste Solvents		N	N	N	S			R	R				N	
*Monoethanolamine*		*R*	*R*	*R*	*R*			*R*	*R*					
Motor Oil		R	R	R	R		R	R	R	R		R	R	
Mustard, yellow							*R*							
*Nickel chloride*		*R*	*R*	*R*	*R*			*R*	*R*				*R*	
*Nickel Sulfate*		*R*	*R*	*R*	*R*			*R*	*R*				*R*	
*Nitric Acid*	10%	*S*	*S*	*S*	*R*		*R*	*S*	*R*	*S*			*R*	
*Nitric Acid*	20%	*S*	*S*	*S*	*R*		*S*	*N*	*R*	*R*	*R*	*R*	*R*	
*Nitric Acid*	30%	*N*	*N*	*N*	*R*			*N*	*R*	*R*	*R*	*R*	*S*	
*Nitric Acid*	40%	*N*	*N*	*N*	*R*			*N*	*S*	*S*	*R*	*S*	*N*	
Oleic Acid		R	R	R	R			R	R				R	
Oxalic Acid	10%	R	R	R	R			R	R				R	
Peppermint Oil	100%	R	R	R	R			R	R	R				
Phenolic Paint stripper waste	1-5%	S	S	S	R			R	R				N	
Phosphoric Acid	85%	*R*	*R*	*R*	*R*		*S*	*R*	*R*	*R*	*R*	*R*	*S*	
Phosphorous Trichloride	100%	N	N	N	S			R	R				N	
PM Solvent		N	N	N	S		R	S	R	R		S	N	
Polyester Resin		S	S	S	R			R	R				S	
Polyester resin in styrene		S	S	S	R			R	R				N	
Polyphosphates		R	R	R	R			R	R	R		R	R	
*Potassium Cyanide*		*R*	*R*	*R*	*R*			*R*	*R*				*R*	
Potassium Hydroxide	45%	R	R	R	R	R		*S*	R	R	R	R	R	
*Potassium Permanganate*	solid	*R*	*R*	*R*	*R*			*S*	*R*	*R*	*R*	*R*	*R*	
Propionic Acid	100%	S	S	S	R			R	R					
Propyl Cellosolve		N	N	N	S			N	R	R	N	N		
Propylene Glycol		R	R	R	R		R	R	R	R	R	R	R	
Propylene glycol ether		N	N	N	R		R		R	R	S	S	R	
Red Wine Vinegar						*S*	R					S		
*Silver Cyanide*		*R*	*R*	*R*	*R*				*R*	*R*				
*Silver Nitrate*	20%	*R*	*R*	*R*	*R*				*R*	*R*	*R*	*R*		
Skydrol		S	S	S	R	S	R	S	R	R		R	R	
Sodium Chlorite		R	R	R	R				R	R	R	R	R	
Sodium Hydroxide	50%	R	R	R	R		R	R	R	R	R	R	R	
Sodium Hypochlorite	15%	R	R	R	R				R	R	R	R	R	
Sodium Hypochlorite	50%	N	N	N	R		R		R	R		R	R	
*Sodium Persulfate*		*R*	*R*	*R*	*R*				*R*	*R*	*R*	*R*	*R*	
*Spearmint Oil*		*S*	S	S	R				R	R				
Spor-Klenz					*N*			*N*					*N*	
Stoddard solvent		N	N	N	S				R	R	N	N	N	
Styrene		N	N	N	S				R	R	N	N	N	
*Sulfuric Acid*	10%	*R*	*R*	*R*	*R*	*R*	*S*	*R*	*R*	*S*	*R*	*R*	*R*	
*Sulfuric Acid*	50%	*N*	*N*	*N*	*R*	N		*S*	*S*	*S*	*R*	*R*	*S*	
*Sulfuric Acid*	75-98%	*N*	*N*	*N*	*R*			*N*	*N*	*N*	*N*	*N*	*N*	
*Tannic Acid*	20%	*R*	*R*	*R*	*R*				*R*	*R*	*R*	*R*		
Tartaric Acid	10%	R	R	R	R				R	R			R	
Terpene Fraction of Spearmint Oil	100%	R	R	R	R				R	R				
Tetrahydrofuran														
Toluol		N	N	N	N				R	R		S		
Transmission Oil		R	R	R	R	S	R		R	R	R	R	R	
Trichloroethane (1,1,1)		S	S	S	R				R	R				
Trichloroethylene		N	N	N	N				R	R	N	S	N	
*Triethanolamine (TEA)*		*S*	*S*	*S*	*R*				R	*S*	R			
*Triethanolpentamine (TEPA)*		*S*	*S*	*S*	*R*				R	*S*				
*Triethanolitetramine (TETA)*		*S*	*S*	*S*	*R*				R	*S*				
Urine		R	R	R	R			R	R	R	R	R	R	
Vinegar		R	R	R	R			R	R	R	R	R	R	
Water		R	R	R	R			R	R	R	R	R	R	
Wine, cabernet sauvignon						*S*	*R*							
Xylene		S	S	S	R		R	S	R	R	S	S	N	

All data is based on room temperature exposure. Please check with the Dur-A-Flex Technical Department for elevated constant temperature or thermal shock exposure

Methodology - Epoxies and Acrylics (MMA) were tested by immersion for Shore D Hardness and weight change at 0, 2, and 7 days

- Urethanes were spot tested and checked after 1, 2, and 7 days

83010

**WHY CLEAN YOUR FLOOR?**

**Appearance:** Your floor will look its best when it is clean. By instituting a scheduled cleaning program, the floor will continue to look and perform as it did when it was first installed.

**Safety:** No matter how aggressive the texture of your floor, if it is not cleaned properly, it can present a slip hazard. Emulsifying, rinsing and drying your floor properly will reduce the risk of a slip and fall incident.

**Service Life:** The lifetime of your floor will depend upon how well you clean it. In aggressive use areas (i.e. kitchens and machine shops) contaminants such as oil, dirt and grease work with water and bacteria to attack your floor.

**FLOOR CLEANING PROCESS & TOOLS**

The best way to clean a Dur-A-Flex floor is to use the recommended cleaning product and follow a six-step process. (Equipment needs vary between small and medium/large floor areas.)

Process	Small Area	Medium/Large Area
<b>Sweep</b> floor thoroughly	Broom, dust mop	Floor sweeper, broom
<b>Apply</b> cleaning product on floor surface	Deck brush, Foamer/sprayer	Automatic floor scrubber, Foamer/sprayer
<b>Dwell</b> – allow cleaning product time to emulsify foreign material	10 –15 minutes	10 –15 minutes
<b>Agitate</b> to aid in the release of foreign materials	Deck brush, Rotary floor machine	Automatic floor scrubber, Rotary floor machine
<b>Remove</b> cleaning product from the floor	Squeegee (soft neoprene) Wet vacuum	Automatic floor scrubber
<b>Rinse</b> the floor with clean water and remove	Wet vacuum, Squeegee (soft neoprene)	Automatic floor scrubber

**NOTES:**

- Never use a mop to clean a floor that is greasy or oily.
- Make sure the pads or brushes on the automatic scrubber are in good shape. Pads should be red or blue 3M cleaning pads or similar. Brushes should be nylon non-abrasive Malish 8129 series or a similar medium flex bristle brush.
- When using a deck brush, choose a medium/stiff bristle.
- When using a rotary floor machine, use a tan or red 3M pad or similar.
- When removing solution with a squeegee, use a soft, neoprene squeegee. **Do Not** use a water spray to remove cleaning solution from the floor because it will over-dilute the solution and cause grease and oil to fall back onto the floor.
- **Wax strippers should never be used on a Dur-A-Flex floor.**
- Spills should be cleaned up immediately to prevent staining and as a safety precaution.
- Surfaces should be adequately protected when moving heavy equipment across the floor.
- Through proper training and education, unnecessary wear of the floor (such as forklift spin and skid-marks) can be avoided.

\*Warranties: Seller warrants that its goods, as described on the face hereof, are free from any defects in material or workmanship. Seller makes no other warranty, express or implied, and all implied warranties of merchantability and fitness for a particular purpose are hereby disclaimed. Seller shall not be liable for prospective profits or special indirect or consequential damages. Seller's sole liability and buyer's exclusive remedy for breach of any warranty as expressly limited, at seller's option, to replacement at the original F.O.B. point or refund of purchase price. Seller shall not be responsible for any claim resulting from failure to utilize product in the manner in which it was intended and in accordance with instruction provided for use of product. Any claim for breach of warranty shall be deemed waived unless buyer shall give seller written notice of such claim within sixty (60) days after delivery and shall allow seller reasonable opportunity to investigate claim and inspect product.\*

## **RECOMMENDED CLEANING PRODUCTS**

Determining the correct cleaning product for your DUR-A-FLEX floor is based upon the amount and type of soiling the floor receives. We have divided these into four types, and recommended a cleaning product for each instance:

<b>Application</b>	<b>Typical Areas</b>	<b>Product</b>	<b>Product Description</b>
Traffic Areas (Light soils)	Retail Hallways, Healthcare, Labs, Dining Areas, Schools	EZ-CLEAN	EZ-CLEAN is a heavy-duty alkaline floor cleaner designed to remove protein or crude based soils.
Moderate/Heavy (Protein soils)	Grocery stores, Restaurant kitchens, Animal care, Food/Beverage Processing	EZ-CLEAN	
Moderate/Heavy (Crude soils)	Manufacturing/Industrial, Machine/Automotive Service Centers, Warehouses	SIMONIZ 969	SIMONIZ 969 is a heavy duty, highly alkaline floor cleaner designed to remove machine and crude oil from concrete
Rubber Tire Marks	Forklift tire spin	TIRE MARK REMOVER	TIRE MARK REMOVER is a heavy duty cleaner designed to remove rubber skid marks from polymer type floors as well as hard steel trowels floors.

The above Dur-A-Flex cleaning products may be ordered directly from Dur-A-Flex Customer Service at 1-800-253-3539 or via email at [orders@dur-a-flex.com](mailto:orders@dur-a-flex.com)

## **WHEN TO CLEAN YOUR FLOOR**

Dur-A-Flex floors are designed for and used in heavy traffic areas that typically accumulate foreign matter. Because of this, the recommended maintenance schedule for most areas is **once or twice daily** cleaning and regular “touch-ups” for spills. Less frequent cleaning of these areas results in a buildup of foreign matter, which diminishes the appearance, safety and service life of the floor.

Our CRYL-A-FLEX MMA products develop to full cure in one hour, and full cure for most epoxy and urethane systems is 7 days at 68°F. The lower the room temperature - the longer the cure time. Avoid chemical spills and full traffic during cure period. Premature exposure may cause permanent staining or discoloration. Do Not use abrasive cleaning methods during the first week after installation.

## **WALL CLEANING PROCESS:**

1. Application – Apply EZ-CLEAN at a 1:64 dilution rate with hot water while using a deck brush, foamer/sprayer or power washer.
2. Scrub walls with deck brush.
3. Rinse walls with clean water.

For further technical assistance regarding this guide, please call DUR-A-FLEX, Inc. Technical Services at (800) 253-3539, or e-mail [info@dur-a-flex.com](mailto:info@dur-a-flex.com).

The two basic joint types are Moving (dynamic) and Non-Moving (static).

## Moving Joints

**Construction, Expansion and Isolation** joints are considered moving joints which allow horizontal and vertical movement between the slab and adjoining structures, such as walls and columns, helping to minimize cracking where the two meet.

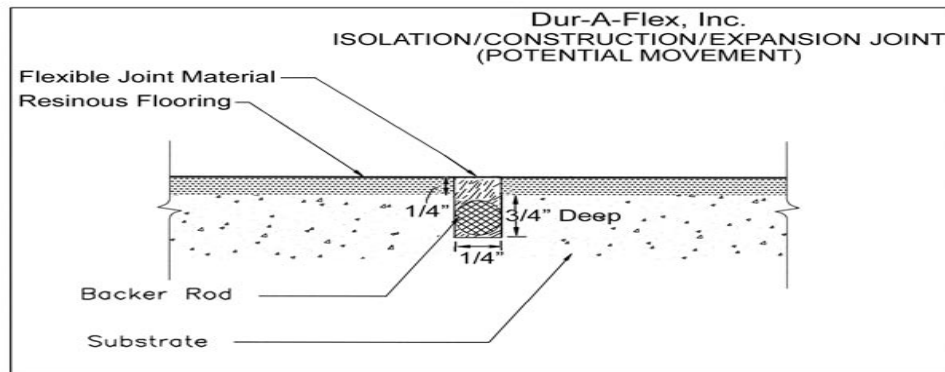

Prior to filling moving joints Dur-A-Flex, Inc. recommends "honoring" these joints by making a saw cut through the finished floor system at a depth of  $\frac{3}{4}$ " deep and  $\frac{1}{4}$ " wide with a diamond blade saw attached to a vacuum. A bond breaker such as backer rod (closed cell) must be added to the bottom of the joint.

**Be sure to mark the location of the joints prior to the installation of the finished floor.**

**Potential cracking and or stress/stretch lines (white lines) may occur on all resinous floor systems over or on either side of moving joints if the joints are not saw cut and properly filled. Also if there is a variance of temperature of 20 degrees or more from the time the joint is filled and coated to its operational temperature, hairline cracking could occur even on non-moving joints.**

## Non-Moving Joints

**Control and or Contraction** joints are considered non-moving joints which accommodate shrinkage and relieve internal stresses during the curing process of the concrete.

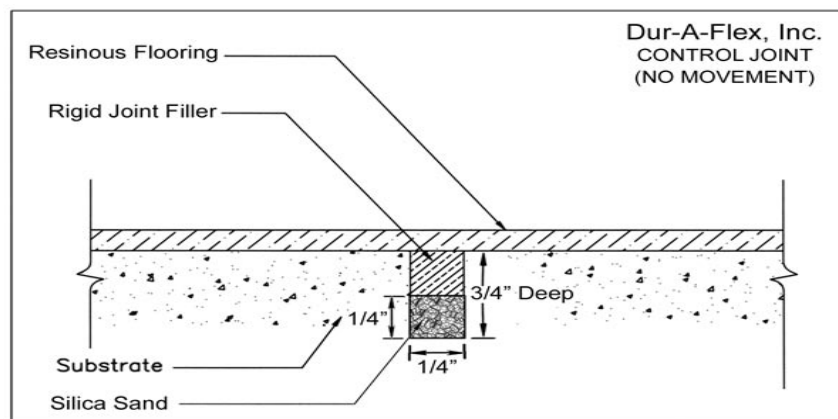

Prior to filling non-moving joints be sure to prepare them by removing all laitance, debris and sealers to a depth of 3/4" deep and 1/4" wide with a diamond blade saw attached to a vacuum. A bond breaker such as silica sand (30-40 mesh) at 1/4" deep may be added to the bottom. This will stop the joint material from seeping if the concrete is cracked through.

**Repair of damaged/spalled joints**

Saw cut each side of spalled area and chip out the center with a chipping hammer or consider the use of a series of blades to reach the proper width. If using multiple blades, the center blade should reach the depth of the original joint and the outer blades should achieve a cut creating a "T" shape after cutting.

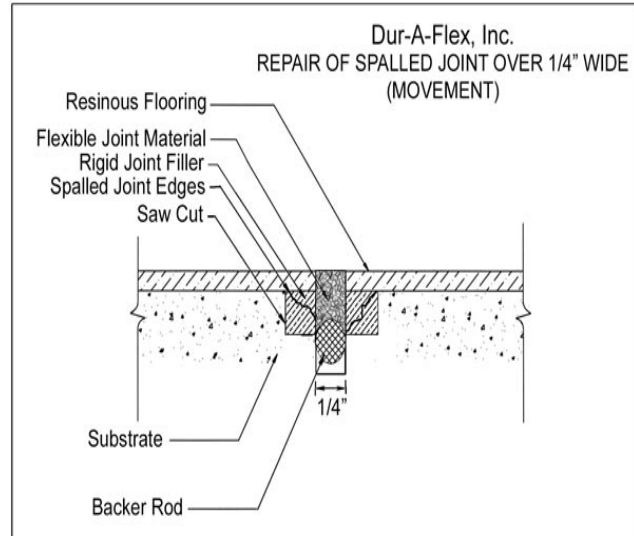
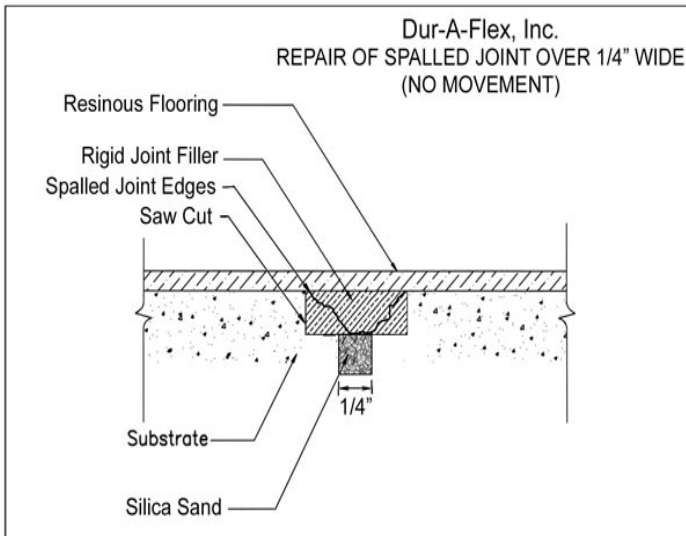

**Installation Timing**

The American Concrete Institute (ACI) recommends that filling of industrial floor joints be deferred 60-90 days after floor slab pour or as long as possible. This is to allow control and construction joints time to open closer to their ultimate width through the concrete shrinkage process. (In freezer/cooler areas, floor should be stabilized at ultimate operating temperature for 7 days prior to installation).

Prior to treatment of joints be sure to contact the facilities owner or manager to determine how long the concrete has cured as well as the location of moving and non-moving joints.

Refer to table below to determine what product is used where:

JOINTS	TYPE	BOND BREAKER	JOINT MATERIAL (1/4 inch wide)	JOINT MATERIAL (over 1/4 inch wide)
Non-moving (Static)	Control/Contraction	Silica Sand (30-40 mesh) at 1/4" deep	<ul style="list-style-type: none"> <li>Epoxy flooring systems use Glaze #4 with Cab-O-Sil (No-Sag #2): Typical mix is 1 pint Glaze #4 hardener, 1 quart Glaze #4 resin, 3 quarts Cab-O-Sil (No-Sag #2)</li> <li>Poly-Crete HF, MD and SL flooring systems typically cover and fill this size crack/joint</li> <li>MMA flooring systems use MMA S/L Filler Mix</li> </ul>	<ul style="list-style-type: none"> <li>Epoxy flooring systems use Glaze #4 with Dur-A-Crete.</li> <li>Poly-Crete flooring systems use Poly-Crete MD or WR</li> <li>MMA flooring systems use SL Filler Mix or Cryl-A-Tex.</li> </ul>
Moving (Dynamic)	Expansion/Construction/ Isolation	Backer Rod 2 X wider than joint	Flexible joint material (Metzger/Mcguire, Versaflex or equivalent)	Flexible joint material (Metzger/Mcguire, Versaflex or equivalent)

**References:**

- ACI 224 "Joints in Concrete Construction"
- ASTM Standards "C 1193-0 and C-920-02"
- National Ready Mixed Concrete Association "Concrete in Practice"
- Metzger/McGuire, Inc.
- SSPC



## Manufacturer's One-Year Limited Warranty

Seller warrants that its goods are free from any defects in material or workmanship and are in conformity with its published specifications, subject to standard tolerances for variations, except that color cannot be warranted as to uniformity of shade or conformity to samples. Seller's sole liability and Customer's exclusive remedy for breach of any warranty as expressly limited, at Seller's option, is to replace material at the original FOB point or refund of the purchase price. A written notice of claim for breach of warranty must be delivered to Seller within sixty (60) days of observation and no more than **one (1) year** after delivery of the product. Seller shall be allowed reasonable opportunity to investigate the claim and inspect the product. In no event may Customer recover damages exceeding the price paid by the Customer for the specific goods as to which the claim is made, whether based on contract, tort, or any other theory.

**SELLER MAKES NO OTHER WARRANTY, EXPRESSED OR IMPLIED, AND ALL IMPLIED WARRANTIES OF FITNESS FOR A PARTICULAR PURPOSE AND OF MERCHANTABILITY ARE HEREBY DISCLAIMED. SELLER SHALL NOT BE LIABLE FOR PROSPECTIVE PROFITS OR SPECIAL, INDIRECT, INCIDENTAL OR CONSEQUENTIAL DAMAGES. ALL WARRANTIES ARE NULL AND VOID IF CUSTOMER HAS NOT PAID IN FULL IN ACCORDANCE WITH SELLER'S PAYMENT TERMS.** Seller shall not be liable for any claim resulting from failure to utilize product in the manner in which it was intended and in accordance with instructions provided for use of product on Dur-A-Flex, Inc.'s web site, product catalogue or otherwise.

Dur-A-Flex, Inc. shall not be liable, and Customer waives all claims made against Dur-A-Flex, Inc. for prospective profits or special, indirect, incidental or consequential damages, or any other damages or remedies not specifically provided above, based upon negligence, breach of warranty, strict liability in tort or any other cause of action. Dur-A-Flex, Inc. will not be liable for, and the Customer shall defend, indemnify and hold harmless (including without limitation costs and attorney's fees) Dur-A-Flex, Inc. from, any loss, damage or injury to persons or property, or claim thereof, resulting from (A) Customer's or any third party's or end user's handling, storage, transportation, resale, application or other use of the goods, or in combination with other substances, or otherwise or (B) selection or recommendation by Dur-A-Flex, Inc. of any applicator or other contractor. Any controversy or claim arising out of or relating to the within Warranty, terms and conditions shall be settled by arbitration in accordance with the commercial arbitration rules of the American Arbitration Association, and judgment upon the award rendered by the arbitrator may be entered in any court having jurisdiction thereof. Venue for the arbitration shall be in Hartford, Connecticut.

Customer & Application:

Agreed and Accepted by:

\_\_\_\_\_  
Patrick J. Meade  
Vice President, Sales & Technical Support

January 1, 2012  
Date

